



SAN DIEGO COUNTY

DEPARTMENT OF PUBLIC WORKS

DESIGN STANDARDS

Published by the Department of Public Works
CIP Project Development Section

November 2009

**SAN DIEGO COUNTY
DEPARTMENT OF PUBLIC WORKS**

INDEX OF DESIGN STANDARDS

<u>NUMBER</u>	<u>TITLE</u>
DS-01	TYPICAL ROADWAY SECTIONS
DS-02	HILLSIDE RESIDENTIAL STREET, ALTERNATIVE NO. 1
DS-03	HILLSIDE RESIDENTIAL STREET, ALTERNATIVE NO. 2
DS-04	HILLSIDE RESIDENTIAL STREET, ALTERNATIVE NO. 3
DS-05	TEMPORARY TURNAROUND AT DEAD END STREET
DS-06	TURNAROUND AND CALCULATIONS
DS-07	ASPHALT CONCRETE DRIVEWAY
DS-08	LOT GRADING
DS-09	FENCING CUT BANKS
DS-10	GRADING OF SLOPES
DS-11	REQUIRED SETBACKS
DS-12	CONSTRUCTION PLAN SYMBOLS
DS-13	STREET NAME SIGN
DS-14	DIP SECTION (PRIVATE STREET)
DS-15	STREET KNUCKLE
DS-16	CLEAR SPACE EASEMENT MARKERS
DS-17	GATED DRIVEWAY ENTRANCE, TYPE I
DS-18	GATED DRIVEWAY ENTRANCE, TYPE II
DS-19	GATED DRIVEWAY ENTRANCE, TYPE III
DS-20A	CLEAR SPACE EASEMENT, TYPE A
DS-20B	CLEAR SPACE EASEMENT, TYPE B
DS-21A	CURB RAMP - TYPES A & B (NEW CONSTRUCTION)
DS-21B	CURB RAMP - TYPES A1 & B1 (FOR EXISTING SIDEWALK)
DS-21C	CURB RAMP – TYPE C (FOR EXISTING SIDEWALK)
DS-21D	CURB RAMP – TYPE D
DS-21E	GENERAL NOTES FOR CURB RAMPS
DS-21F	CURB RAMP DETAILS
DS-22	TRENCH RESURFACING TYPE-R

ROADWAY SECTION
SYMMETRICAL ABOUT CENTERLINE

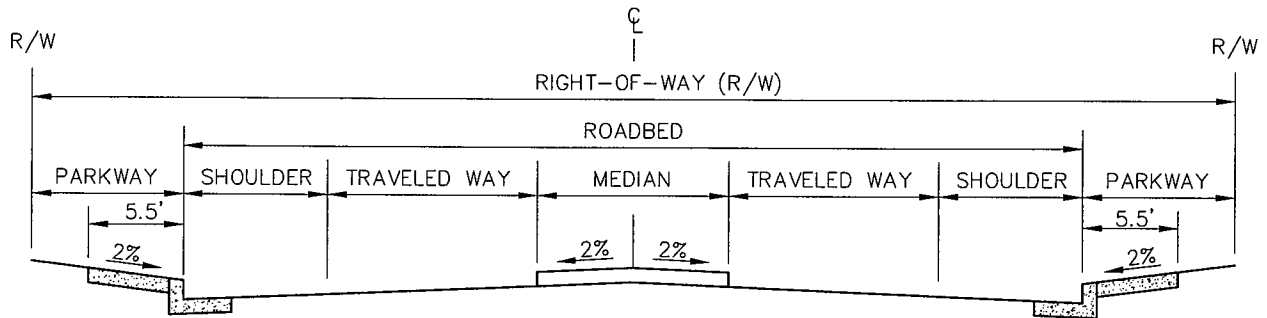

ROAD CLASSIFICATION	TRAVELED WAY NUMBER OF LANES/WIDTH	R/W WIDTHS (2,3,4)	ROAD SURFACING WIDTH (2,3,4)	PAVED SHOULDER NO./ WIDTH	PARKWAY WIDTH
CIRCULATION ELEMENT					
EXPRESSWAY	6/12+34' MEDIAN	146'	126'	2/10'	10'
PRIME ARTERIAL	6/12+14' MEDIAN	122'	102'	2/8'	10'
MAJOR ROAD	4/12+14' MEDIAN	98'	78'	2/8'	10'
COLLECTOR	4/12'	84'	64'	2/8'	10'
TOWN COLLECTOR	2+12' MEDIAN	74'	54'	2/8'	10'
LIGHT COLLECTOR	2/12'	60'	40'	2/8'	10'
RURAL COLLECTOR	2/12'	84'	40'	2/8'	22'
RURAL LIGHT COLLECTOR	2/12'	60'	40'	2/8'	10'
RECREATIONAL PARKWAY	2/12'	100'	40'	2/8'	30'
RURAL MOUNTAIN	2/12'	100'	40'	2/8'	30'
NON-CIRCULATION ELEMENT					
RESIDENTIAL COLLECTOR	2/12'	60'	40'	2/8'	10'
RESIDENTIAL	2/12'	56'	36'	2/6'	10'
RESIDENTIAL CUL-DE-SAC	2/12'	52'	32'	2/4'	10'
RESIDENTIAL LOOP	2/12'	52'	32'	2/4'	10'
INDUSTRIAL/COMMERCIAL COLLECTOR	4/12'	88'	68'	2/10'	10'
INDUSTRIAL/COMMERCIAL	2/16'	72'	52'	2/10'	10'
INDUSTRIAL/COMMERCIAL CUL-DE-SAC	2/16'	72'	52'	2/10'	10'
FRONTAGE	2/12'	52' MIN	32' MIN	1/8'	10'
ALLEY	2/10'	20'-30'	20'-30'	NONE	NONE
SPLIT-LEVEL	SEE NOTE 1	---	---	---	---

NOTES:

- REFER TO SAN DIEGO COUNTY DESIGN STANDARDS DS-02, DS-03, DS-04, AND COUNTY OF SAN DIEGO PUBLIC ROAD STANDARDS.
- ADDITIONAL ROAD SURFACING AND R/W MAY BE REQUIRED FOR CIRCULATION ELEMENT COLLECTORS AND LIGHT COLLECTORS IN INDUSTRIAL/COMMERCIAL ZONES (4 FEET AND 12 FEET RESPECTIVELY).
- CIRCULATION ELEMENT ROADS NEEDING ADDITIONAL TURN LANES WILL REQUIRE AN ADDITIONAL 12 TO 14 FEET OF ROAD SURFACING AND R/W FOR EACH LANE.
- CIRCULATION ELEMENT ROADS DESIGNATED WITH BIKE LANES WILL REQUIRE AN ADDITIONAL 10-12 FEET OF ROAD SURFACING AND R/W. THROUGH TRAFFIC LANES ADJACENT TO BIKE LANES MAY ALSO REQUIRE 13 FEET WIDE LANES. REFER TO COUNTY OF SAN DIEGO PUBLIC ROAD STANDARDS, SECTION 7, "BIKEWAYS".
- INTERIM ROADS SHALL HAVE A MINIMUM WIDTH OF 28 FEET OF A.C. ROAD SURFACING WITHIN 40 FEET OF GRADED ROAD BED. WIDTHS WILL BE LARGER IF TRAFFIC VOLUMES REQUIRE MORE TRAVEL LANES.

DRAWN BY: <u>SS</u>	CHECKED BY: <u>JMC</u>	SAN DIEGO COUNTY DESIGN STANDARD TYPICAL ROADWAY SECTIONS	REVISION	APPROVED	DATE
RECOMMENDED BY: <u>JEFF S. MOODY</u>					
APPROVED BY: 					
DOUGLAS M. ISBELL, COUNTY ENGINEER					
RCE# <u>18634</u> EXP. <u>06/2007</u>			DRAWING NUMBER	DS-01	

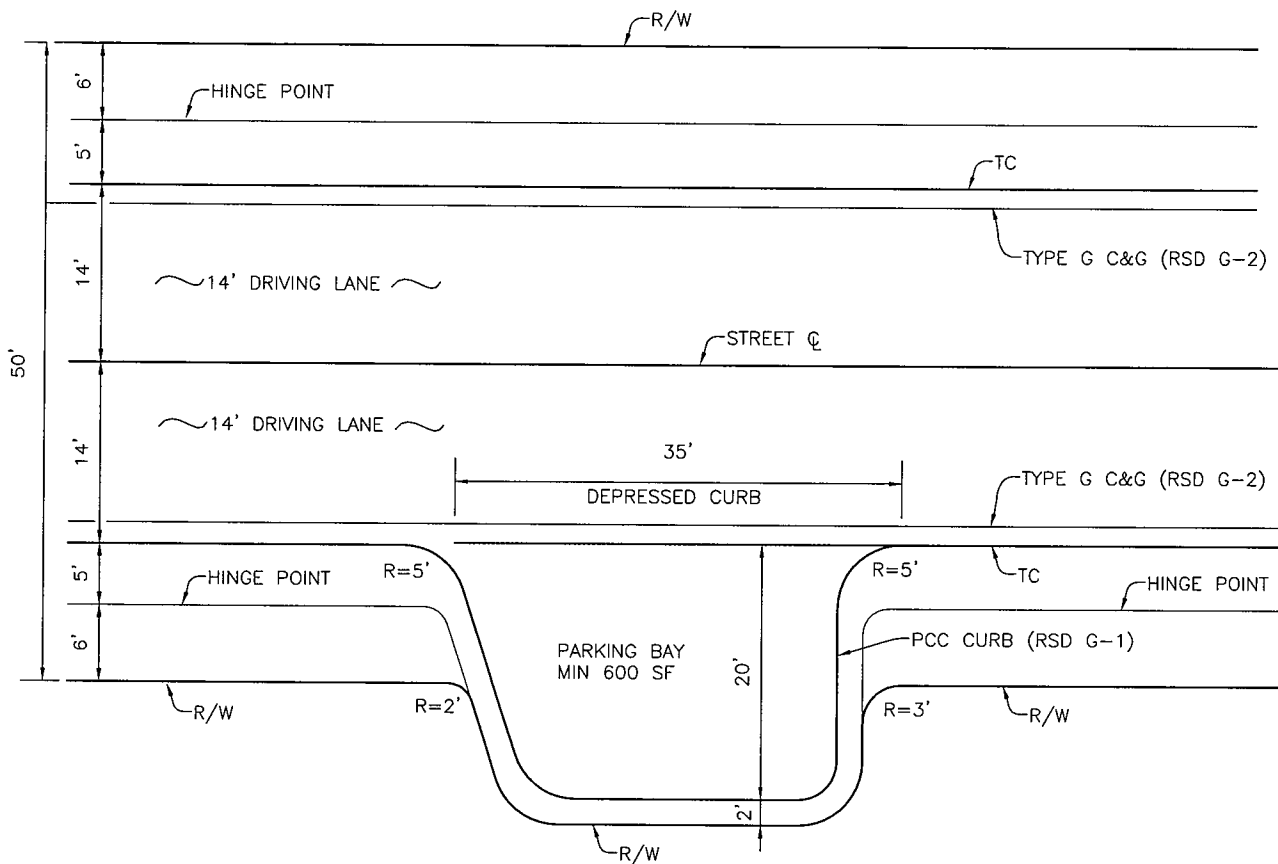

PLAN
NO SCALE

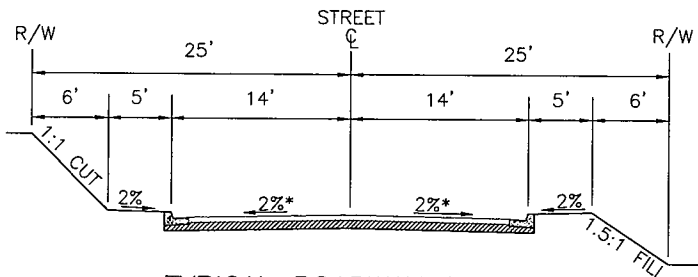

TYPICAL ROADWAY SECTION
NO SCALE

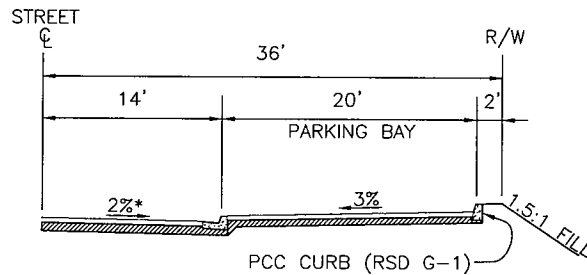

TYPICAL PARKING BAY SECTION
NO SCALE

* MAX 3% CROSSFALL/SUPERELEVATION

NOTES:

1. THIS STANDARD IS APPLICABLE ONLY TO CATEGORY 2 HILLSIDE RESIDENTIAL STREETS AS DEFINED IN COUNTY OF SAN DIEGO PUBLIC ROAD STANDARDS SECTION 4.5 N.
2. USE OF HILLSIDE RESIDENTIAL STREET STANDARDS ARE APPLICABLE ONLY TO NON-CIRCULATION ELEMENT STREETS CLASSIFIED AS RESIDENTIAL, RESIDENTIAL CUL-DE-SAC, OR RESIDENTIAL LOOP STREETS, AND ARE NOT APPLICABLE TO STREETS IN AREAS ZONED FOR COMMERCIAL, INDUSTRIAL OR MULTIPLE RESIDENTIAL USE.
3. CURB AND GUTTER (C&G) SHALL CONFORM TO SAN DIEGO AREA REGIONAL STANDARD DRAWINGS (RSD) AND COUNTY OF SAN DIEGO PUBLIC ROAD STANDARDS.
4. ONE 600 SQUARE FEET PERPENDICULAR PARKING BAY REQUIRED PER LOT. THE COUNTY ENGINEER MAY ALSO ESTABLISH ALTERNATE STANDARD TYPICAL SECTIONS WHICH WILL PROVIDE A MINIMUM OF TWO PARKING STALLS PER LOT.

DRAWN BY: SS	CHECKED BY: LMC
RECOMMENDED BY: JEFF S. MOODY	
APPROVED BY: <i>[Signature]</i>	
DOUGLAS M. ISBELL, COUNTY ENGINEER	
RCE# 18634	EXP. 06/2007

SAN DIEGO COUNTY DESIGN STANDARD
HILLSIDE RESIDENTIAL STREET
ALTERNATIVE NO. 1

REVISION	APPROVED	DATE
DRAWING NUMBER	DS-02	

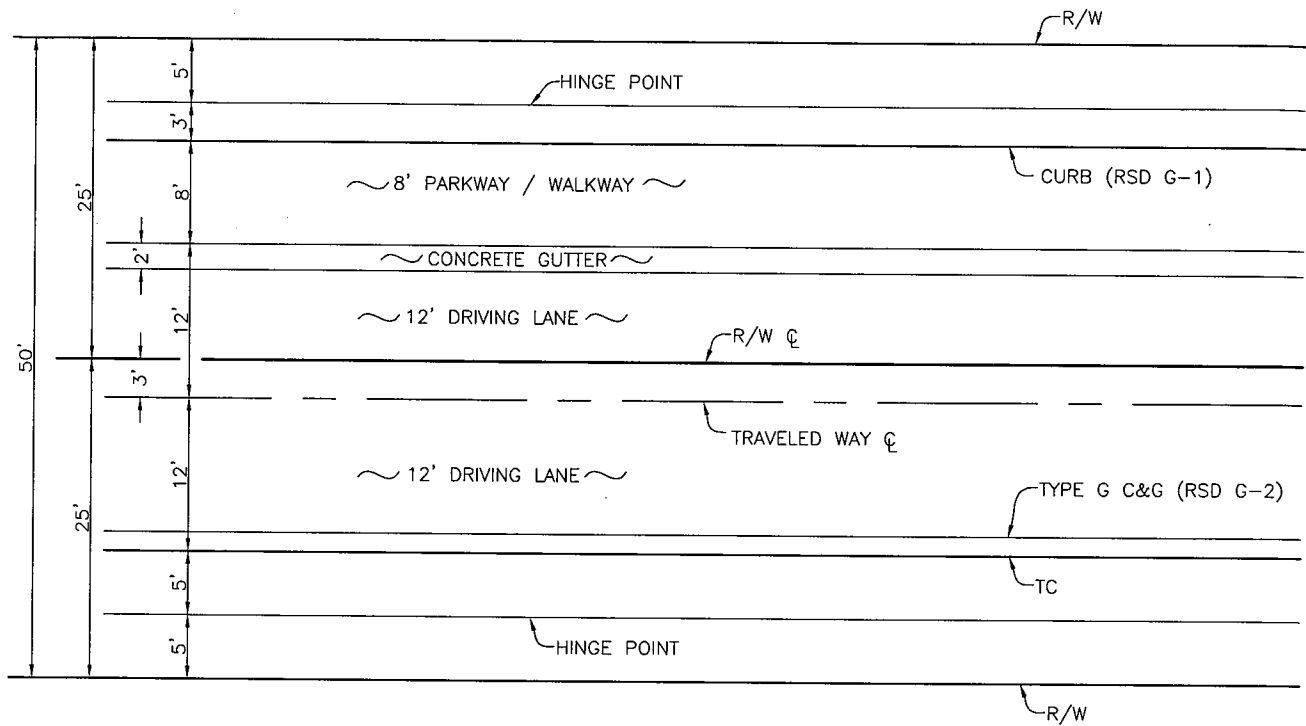

PLAN
NO SCALE

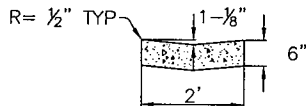

CONCRETE GUTTER DETAIL
NO SCALE

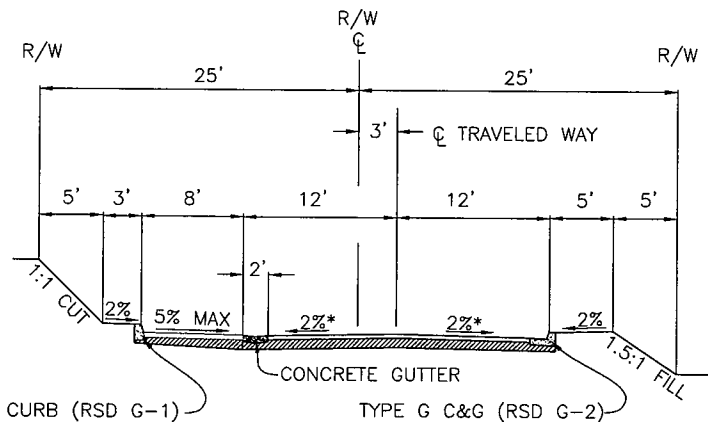

* MAX 3% CROSSFALL / SUPERELEVATION

TYPICAL ROADWAY SECTION
NO SCALE

NOTES:

1. THIS STANDARD IS APPLICABLE ONLY TO CATEGORY 2 HILLSIDE RESIDENTIAL STREETS AS DEFINED IN COUNTY OF SAN DIEGO PUBLIC ROAD STANDARDS SECTION 4.5 N.
2. USE OF HILLSIDE RESIDENTIAL STREET STANDARDS ARE APPLICABLE ONLY TO NON-CIRCULATION ELEMENT STREETS CLASSIFIED AS RESIDENTIAL, RESIDENTIAL CUL-DE-SAC, OR RESIDENTIAL LOOP STREETS, AND ARE NOT APPLICABLE TO STREETS IN AREAS ZONED FOR COMMERCIAL, INDUSTRIAL OR MULTIPLE RESIDENTIAL USE.
3. CURB AND GUTTER (C&G) SHALL CONFORM TO SAN DIEGO AREA REGIONAL STANDARD DRAWINGS (RSD) AND COUNTY OF SAN DIEGO PUBLIC ROAD STANDARDS.

DRAWN BY: SS	CHECKED BY: LMC
RECOMMENDED BY: JEFF S. MOODY	
APPROVED BY: <i>D.M. Isbell</i>	
DOUGLAS M. ISBELL, COUNTY ENGINEER	
RCE# 18634	EXP. 06/2007

SAN DIEGO COUNTY DESIGN STANDARD	
HILLSIDE RESIDENTIAL STREET ALTERNATIVE NO. 2	

REVISION	APPROVED	DATE
DRAWING NUMBER		DS-03

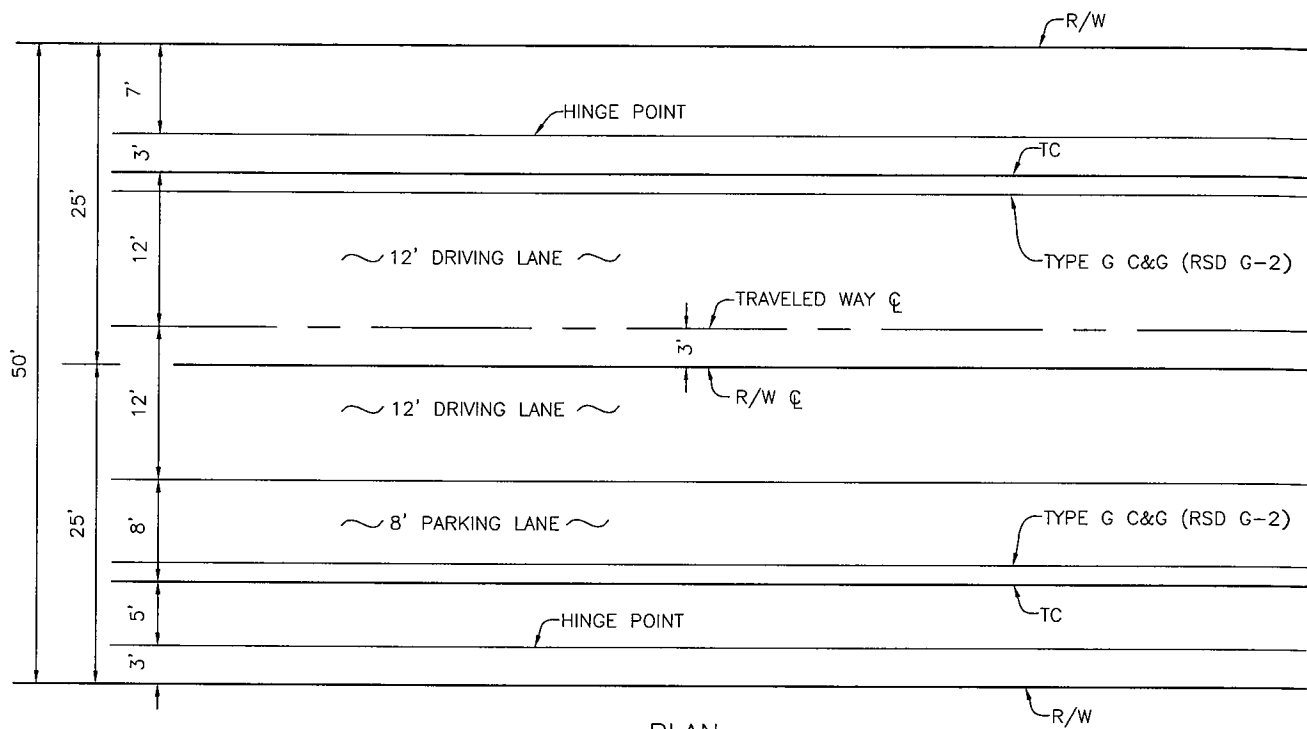

PLAN
NO SCALE

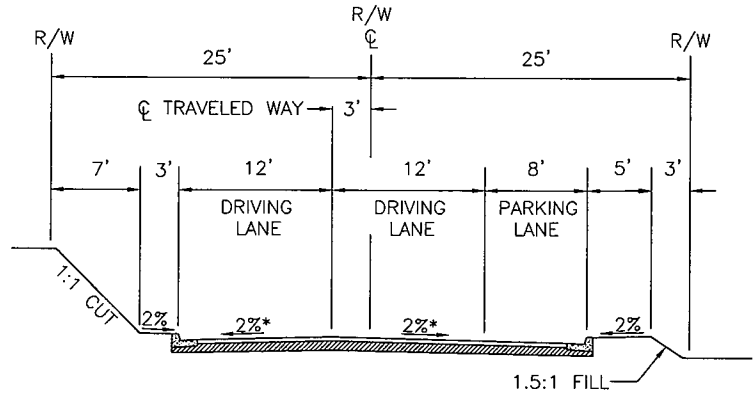

* MAX 3% CROSSFALL /SUPERELEVATION

TYPICAL ROADWAY SECTION
NO SCALE

NOTES:

1. THIS STANDARD IS APPLICABLE ONLY TO CATEGORY 2 HILLSIDE RESIDENTIAL STREETS AS DEFINED IN COUNTY OF SAN DIEGO PUBLIC ROAD STANDARDS SECTION 4.5 N.
2. USE OF HILLSIDE RESIDENTIAL STREET STANDARDS ARE APPLICABLE ONLY TO NON-CIRCULATION ELEMENT STREETS CLASSIFIED AS RESIDENTIAL, RESIDENTIAL CUL-DE-SAC, OR RESIDENTIAL LOOP STREETS, AND ARE NOT APPLICABLE TO STREETS IN AREAS ZONED FOR COMMERCIAL, INDUSTRIAL OR MULTIPLE RESIDENTIAL USE.
3. CURB AND GUTTER (C&G) SHALL CONFORM TO SAN DIEGO AREA REGIONAL STANDARD DRAWINGS (RSD) AND COUNTY OF SAN DIEGO PUBLIC ROAD STANDARDS.

DRAWN BY: <u>SS</u>	CHECKED BY: <u>JMC</u>	SAN DIEGO COUNTY DESIGN STANDARD	REVISION	APPROVED	DATE
RECOMMENDED BY: <u>JEFF S. MOODY</u>					
APPROVED BY: <u>D. M. Isbell</u>		HILLSIDE RESIDENTIAL STREET ALTERNATIVE NO. 3			
DOUGLAS M. ISBELL, COUNTY ENGINEER					
RCE# <u>18634</u> EXP. <u>06/2007</u>			DRAWING NUMBER <u>DS-04</u>		

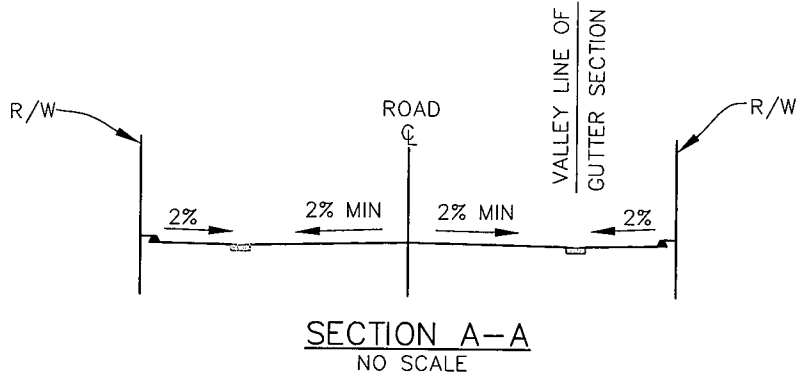

LEGEND

- (A) PROVIDE DIKE OPENING FOR DRAINAGE WHEN REQUIRED.
- (B) PERMANENT STREET SURFACING.
- (C) CONCRETE GUTTER (SEE DETAIL).
- (D) TYPE G C&G (RSD G-2).
- (E) TYPE B DIKE (RSD G-5).
- (F) SUBDIVISION LINE.
- (G) GUARD POST BARRICADE (RSD M-9)

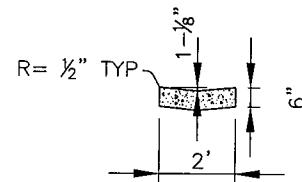

CONCRETE GUTTER DETAIL
NO SCALE

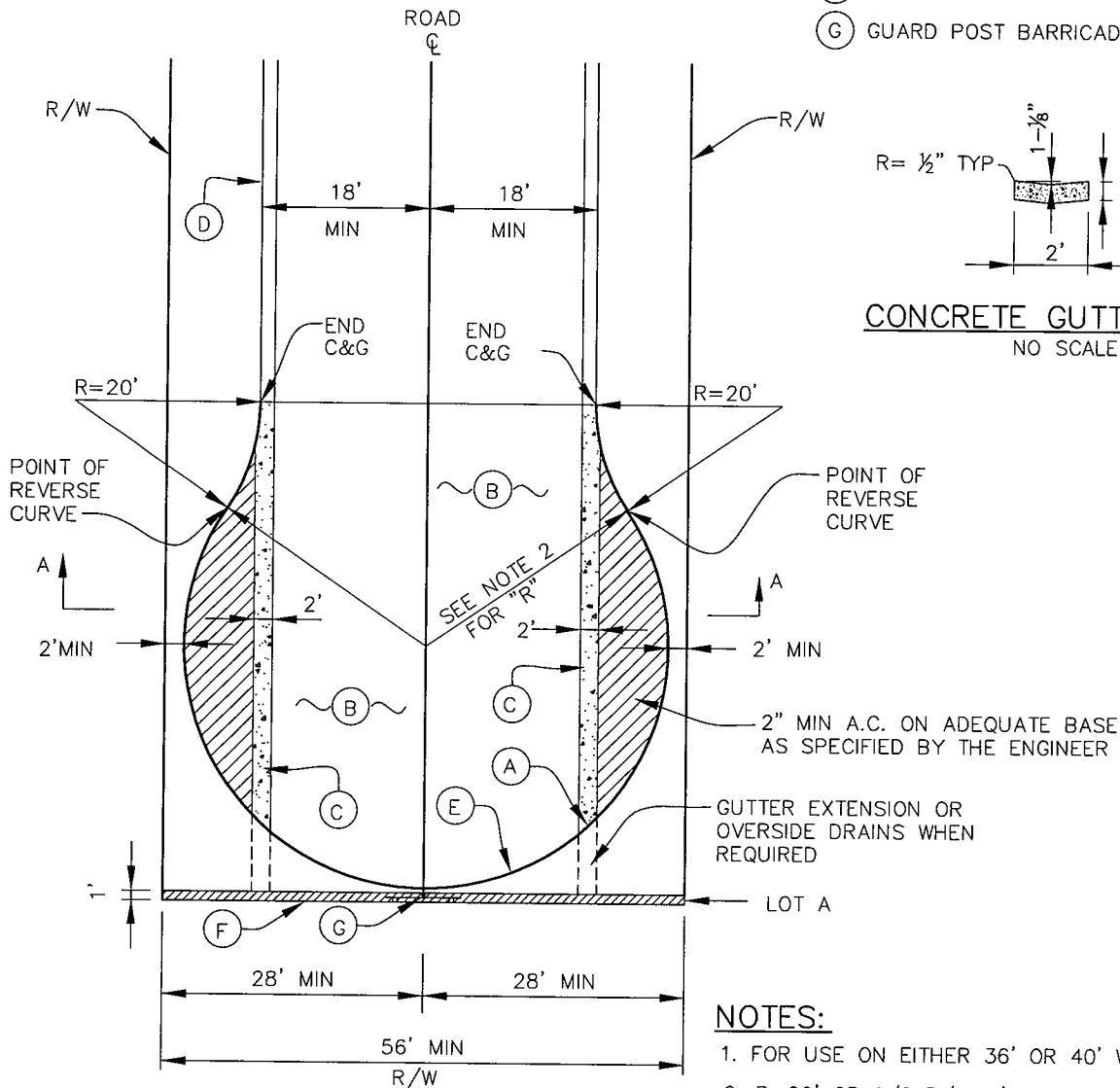

TEMPORARY TURNAROUND
NO SCALE

NOTES:

1. FOR USE ON EITHER 36' OR 40' WIDE STREETS.
2. R=26' OR 1/2 R/W-2' WHICHEVER IS GREATER.

DRAWN BY: <u>SS</u>	CHECKED BY: <u>LMC</u>
RECOMMENDED BY: <u>JEFF S. MOODY</u>	
APPROVED BY: <u>[Signature]</u>	
DOUGLAS M. ISBELL, COUNTY ENGINEER	
RCE# <u>18634</u>	EXP. <u>06/2007</u>

SAN DIEGO COUNTY DESIGN STANDARD

**TEMPORARY TURNAROUND
AT DEAD END STREET**

REVISION	APPROVED	DATE

DRAWING NUMBER **DS-05**

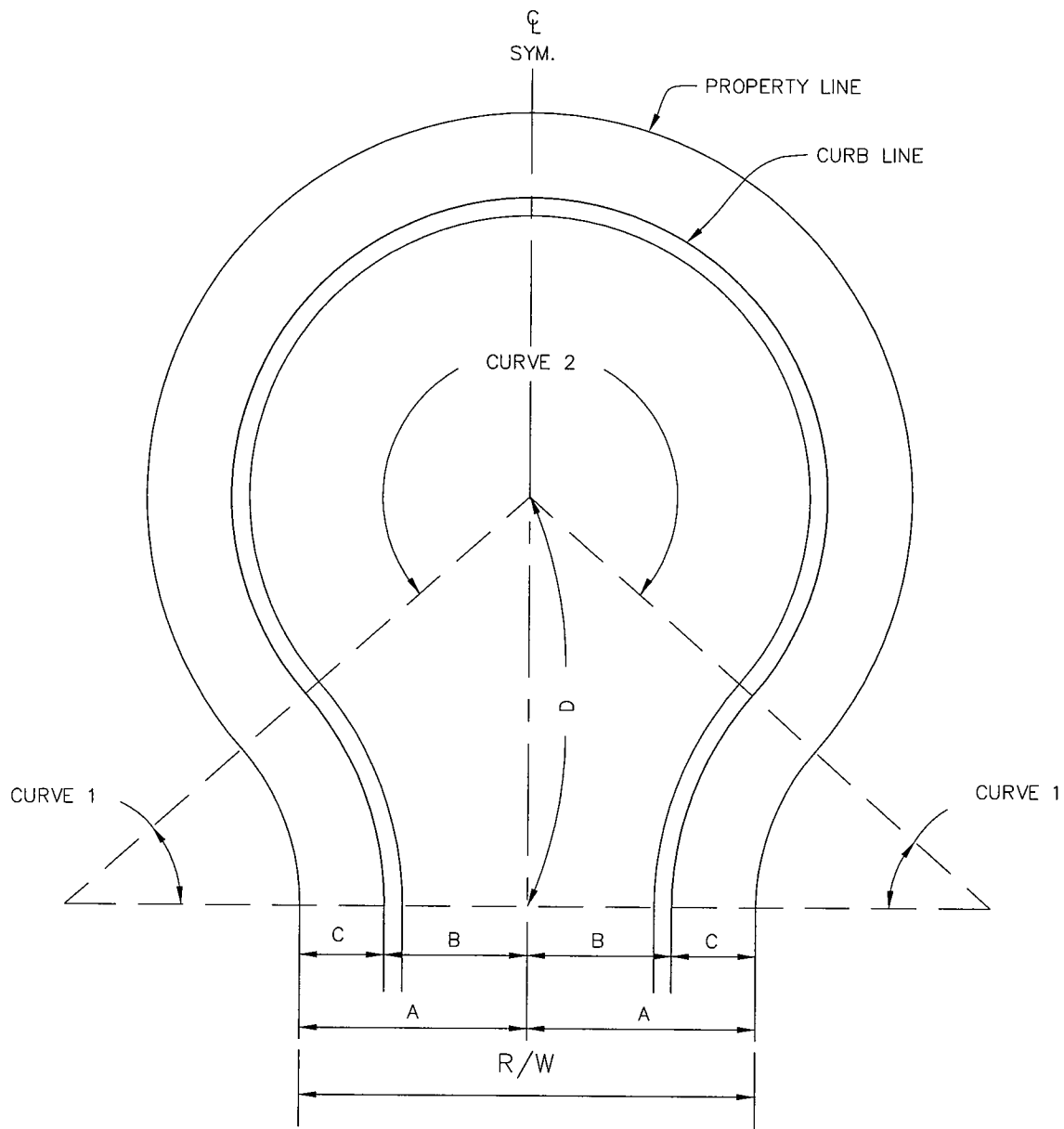

TURNAROUND
NO SCALE

DIMENSIONS					CURVE 1						CURVE 2					
R/W	A	B	C	D	△	CURB			PROP.			△	CURB		PROP.	
						R	L	T	R	L	T		R	L	R	L
52'	26'	16'	10'	50.95'	46° 42' 30"	32'	26.09'	13.82'	22'	17.93'	9.50'	273° 25' 00"	38'	181.34'	48'	229.06'
56'	28'	18'	10'	50.99'	42° 50' 00"	37'	27.66'	14.52'	27'	20.18'	10.59'	265° 40' 00"	38'	176.20'	48'	222.56'
60'	30'	20'	10'	68.15'	29° 35' 31"	100'	51.65'	26.41'	90'	46.48'	23.77'	239° 11' 02"	38'	158.63'	48'	200.38'
72'	36'	26'	10'	81.39'	32° 51' 36"	100'	57.35'	29.49'	90'	51.62'	26.54'	245° 43' 12"	50'	214.43'	60'	257.32'

DRAWN BY: SS CHECKED BY: LMC
 RECOMMENDED BY: JEFF S. MOODY
 APPROVED BY: *Douglas M. Isbell*
 DOUGLAS M. ISBELL, COUNTY ENGINEER
 RCE# 18634 EXP. 06/2007

SAN DIEGO COUNTY DESIGN STANDARD

TURNAROUND
AND CALCULATIONS

REVISION	APPROVED	DATE

DRAWING NUMBER **DS-06**

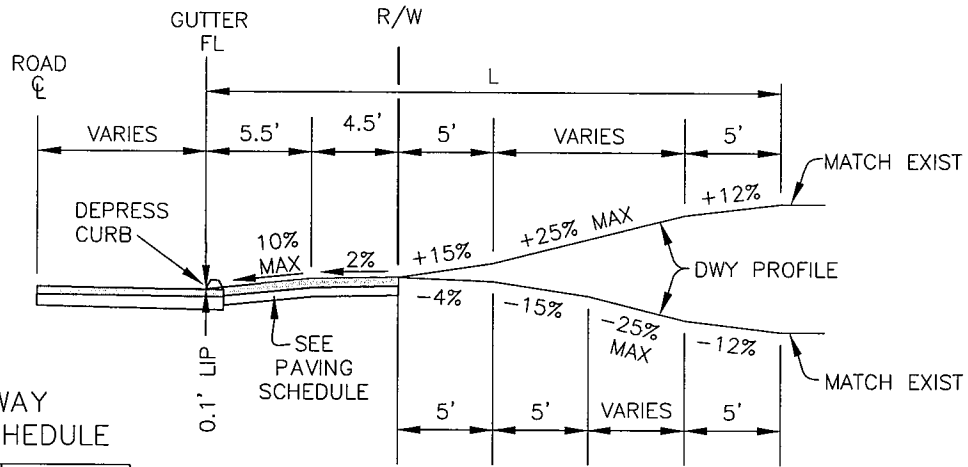

DRIVEWAY PAVING SCHEDULE

DEPTH OF A.C.	GRADE
0.17' (2")	0-15%
0.25' (3")	15-20%
0.33' (4")	20-25%

ALL AC OVER 0.33' (4")
MINIMUM CL II AB

COMPACT ENTIRE STRUCTURAL SECTION TO 95% RELATIVE COMPACTION

PROFILE
NO SCALE

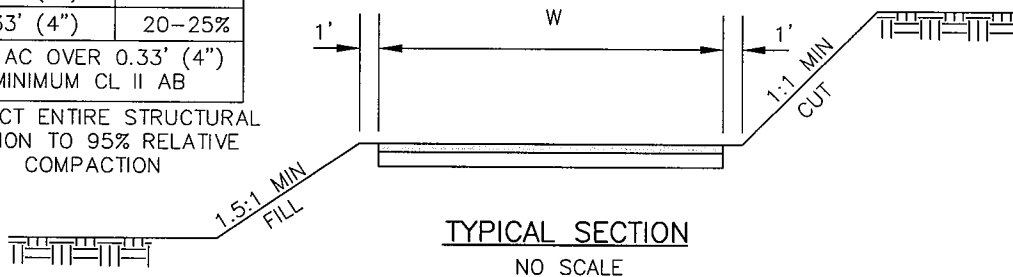

TYPICAL SECTION
NO SCALE

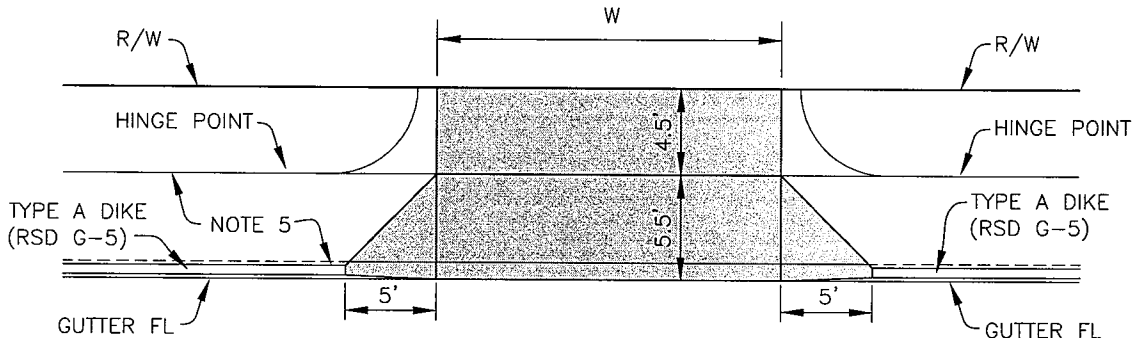

PLAN
NO SCALE

NOTES:

1. DRIVEWAY PROFILE, WIDTH (W) AND LENGTH (L) SHALL BE SHOWN ON PLANS.
2. DRIVEWAYS WITH GRADES GREATER THAN 15% SHALL BE SURFACED WITH ASPHALT CONCRETE (AC) OR PORTLAND CEMENT CONCRETE (PCC).
3. MAXIMUM GRADE BREAK 14% (5' MINIMUM VERTICAL CURVE PREFERRED).
4. SEE SAN DIEGO AREA REGIONAL STANDARD DRAWINGS G-15 & G-16 FOR DRIVEWAY LOCATION & WIDTH REQUIREMENTS AND G-14 SERIES FOR PCC DRIVEWAYS.
5. PLACE 0.17' (2") THICKNESS OF A.C. BETWEEN DIKE AND HINGE POINT FOR 15 LF ON THE DOWNSLOPE WALKWAY WHEN ROADWAY SLOPE EXCEEDS 5%.
6. ALL DRIVEWAYS SHALL SATISFY COUNTY SIGHT DISTANCE REQUIREMENTS.

DRAWN BY: <u>SS</u>	CHECKED BY: <u>LMC</u>	SAN DIEGO COUNTY DESIGN STANDARD	REVISION	APPROVED	DATE	
RECOMMENDED BY: <u>JEFF S. MOODY</u>			<u>1</u>		<u>9/14/06</u>	
APPROVED BY: <u>[Signature]</u>		ASPHALT CONCRETE DRIVEWAY				
MOHAMAD FAKHRRIDDINE, COUNTY ENGINEER			DRAWING NUMBER	DS-07		
RCE# <u>44520</u> EXP. <u>03/31/08</u>						

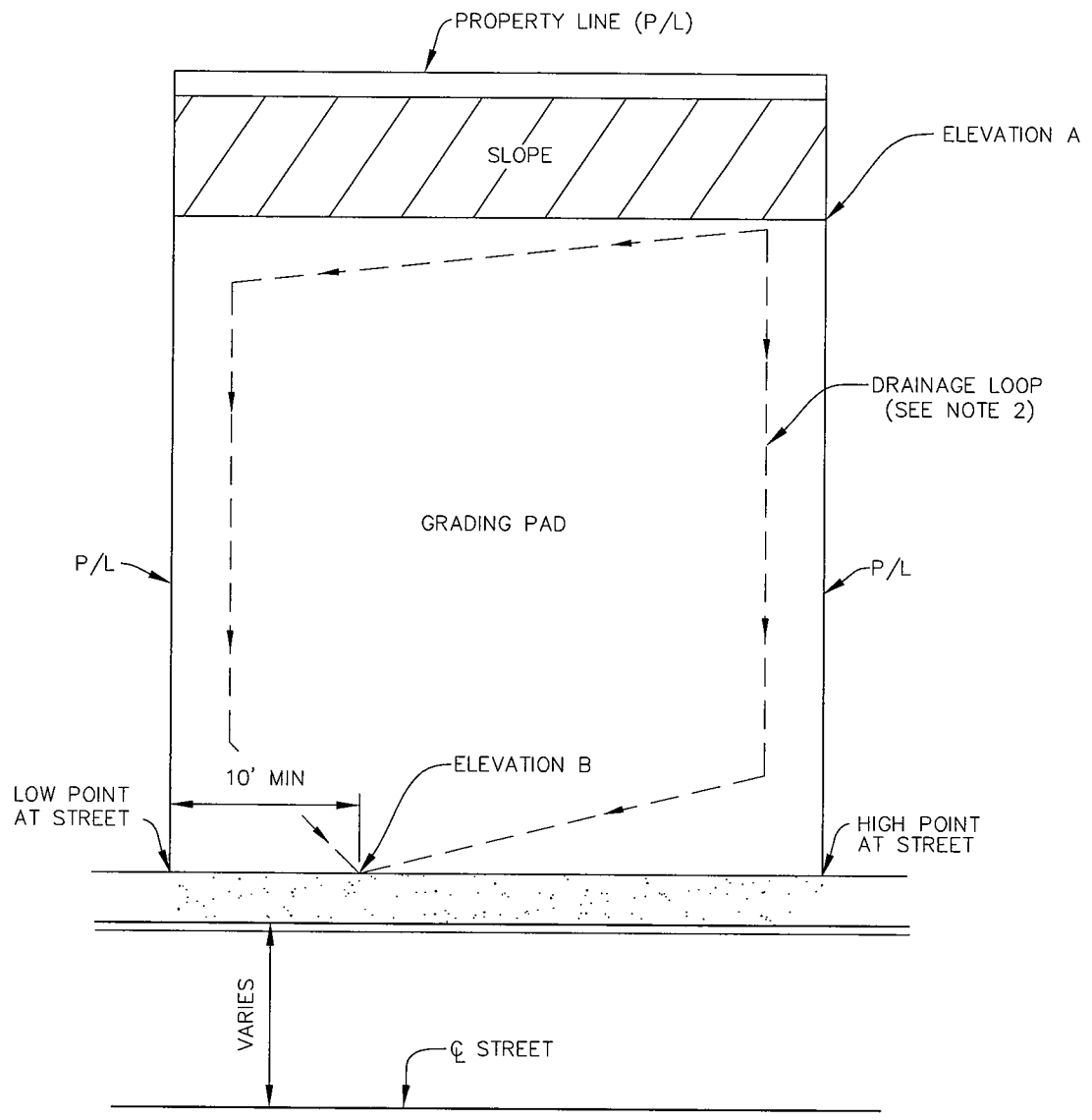

TYPICAL FINISHED GRADING

NO SCALE

NOTES:

1. ELEVATION "A" IS LOCATED AT THE MOST REMOTE CORNER OF THE LOT FROM THE DRAIN POINT "B". ELEVATION "A" SHALL EQUAL ELEVATION "B" PLUS 1% TIMES ONE-HALF THE PERIMETER OF THE LOT.
2. MINIMUM 1% SWALE TO STREET OR OTHER DISCHARGE POINT.
3. ALL SLOPE SURFACES SHALL BE PROTECTED BY APPROVED EROSION CONTROL MATERIAL.

DRAWN BY: SS CHECKED BY: LMC

RECOMMENDED BY: JEFF S. MOODY

APPROVED BY: *[Signature]*

DOUGLAS M. ISBELL, COUNTY ENGINEER

RCE# 18634 EXP. 06/2007

SAN DIEGO COUNTY DESIGN STANDARD

LOT GRADING

REVISION	APPROVED	DATE

DRAWING NUMBER **DS-08**

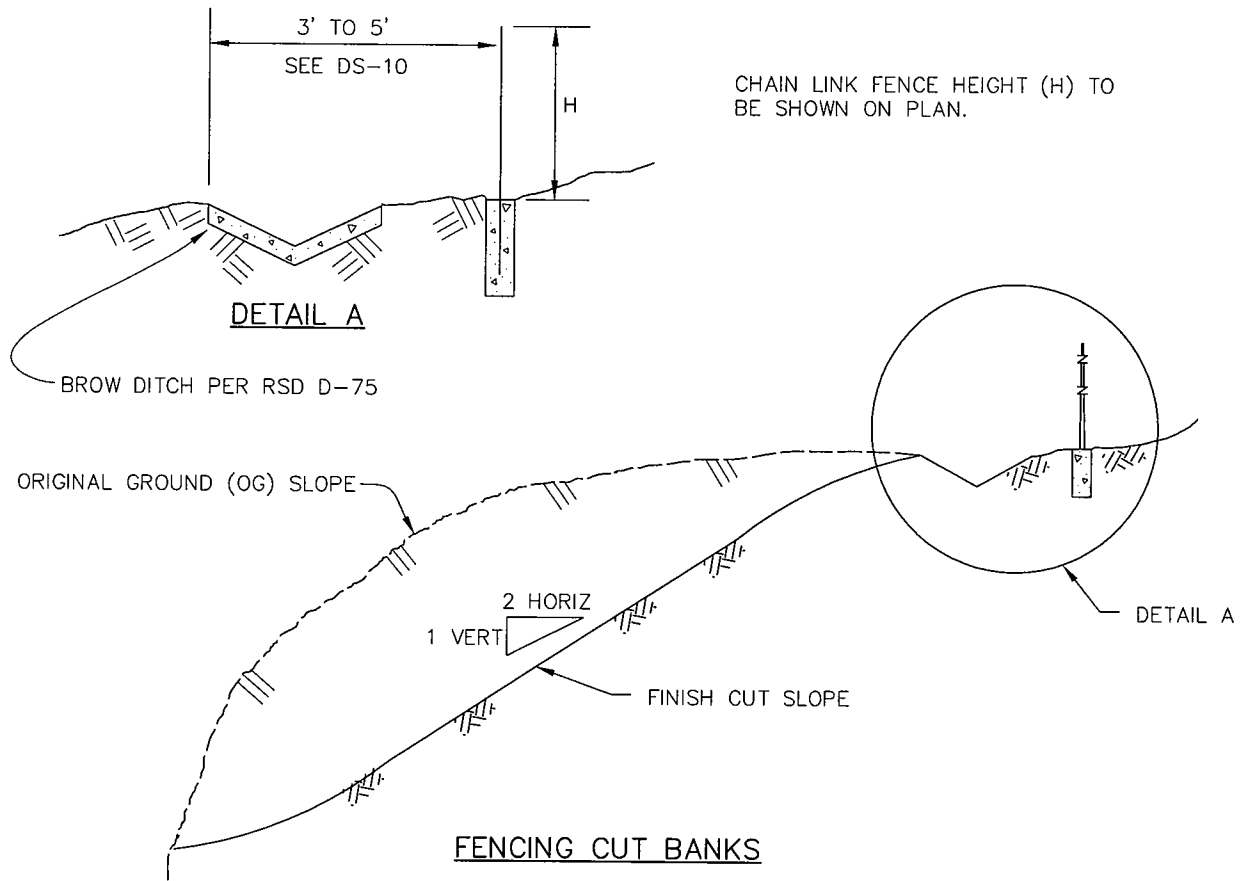

CHAIN LINK FENCE HEIGHT (H) TO BE SHOWN ON PLAN.

DETAIL A

BROW DITCH PER RSD D-75

ORIGINAL GROUND (OG) SLOPE

2 HORIZ
1 VERT

FINISH CUT SLOPE

DETAIL A

FENCING CUT BANKS

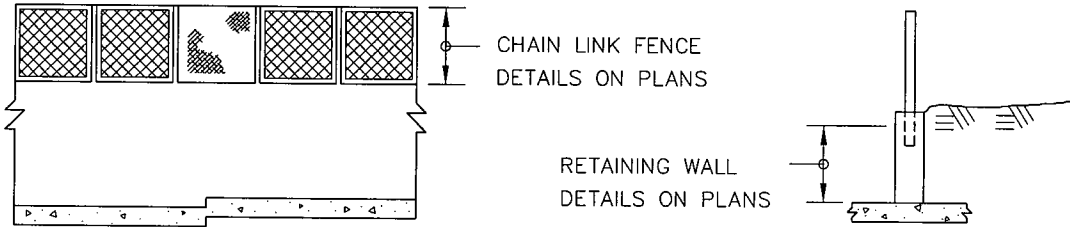

CHAIN LINK FENCE
DETAILS ON PLANS

RETAINING WALL
DETAILS ON PLANS

RETAINING WALL & CHAIN LINK FENCE
FOR WALL HEIGHTS GREATER THAN 4 FT.

NOTES:

1. CHAIN LINK FENCE OR ALTERNATE ACCEPTABLE TO THE COUNTY ENGINEER SHALL BE INSTALLED ALONG THE TOP OF SLOPES EXCEEDING 15 FEET VERTICAL HEIGHT AND 3 : 1 (HORIZONTAL : VERTICAL) SLOPE RATIO AND ALONG THE TOP OF ALL WALLS EXCEEDING 4' VERTICAL HEIGHT
2. RETAINING WALLS AND CHAIN LINK FENCE OR ALTERNATE SHALL BE CONSTRUCTED IN ACCORDANCE WITH SAN DIEGO AREA REGIONAL STANDARD DRAWINGS (RSD).

DRAWN BY: <u>SS</u>	CHECKED BY: <u>LMC</u>	SAN DIEGO COUNTY DESIGN STANDARD	REVISION	APPROVED	DATE
RECOMMENDED BY: <u>JEFF S. MOODY</u>					
APPROVED BY: <u>D. M. Isbell</u>		FENCING CUT BANKS			
DOUGLAS M. ISBELL, COUNTY ENGINEER					
RCE# <u>18634</u> EXP. <u>06/2007</u>			DRAWING NUMBER <u>DS-09</u>		

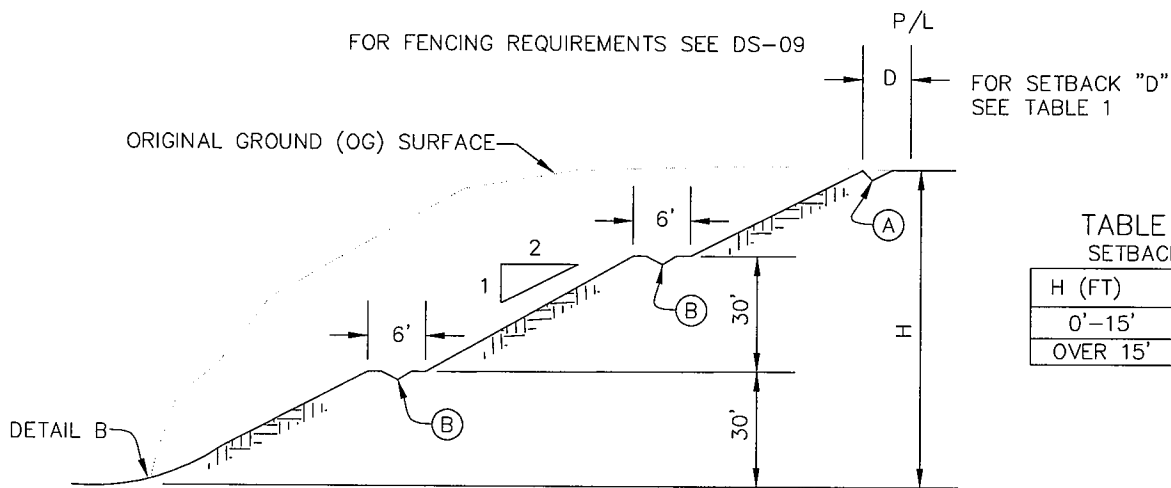
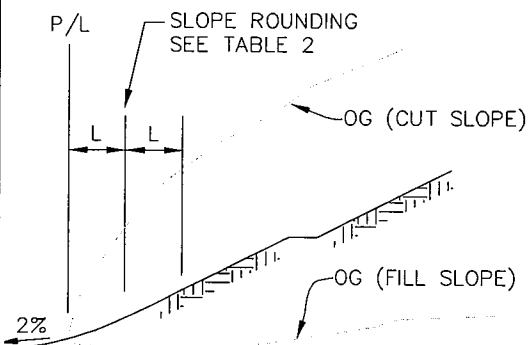

TABLE 1
SETBACK

H (FT)	D (FT)
0'-15'	3'
OVER 15'	5'

TYPICAL CUT SLOPE
NO SCALE



DETAIL B
NO SCALE

TABLE 2
SLOPE ROUNDING

H FEET	L FEET
0'-5'	-
5'-20'	2.5'
20'-40'	5'
OVER 40'	10'

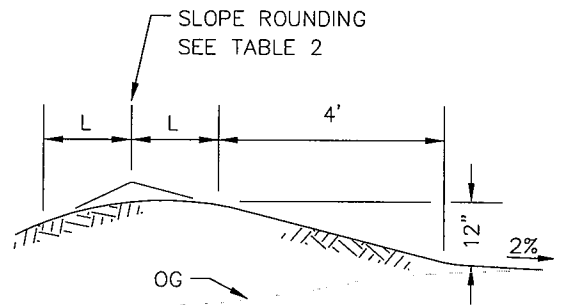

DETAIL C
NO SCALE

NOTES:

- (A) BROW DITCH PER RSD D-75
- (B) TERRACE DITCH PER RSD D-75
- (C) REMOVE SOIL MANTLE
- (D) BENCHES REQUIRED FOR ORIGINAL GROUND SLOPE GREATER THAN 5:1

ALL FILL MUST BE COMPACTED TO A MINIMUM 90% RELATIVE COMPACTION (RC) EXCEPT FOR THE OUTER 8" OF SLOPE SURFACE WHICH MAY BE GRID ROLLED TO 85% RC

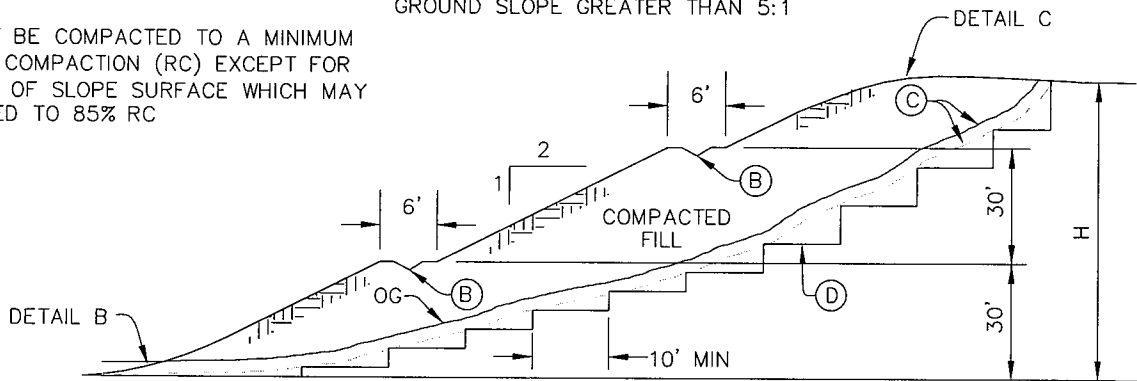

TYPICAL FILL SLOPE
NO SCALE

DRAWN BY: SS	CHECKED BY: JMC
RECOMMENDED BY: JEFF S. MOODY	
APPROVED BY: <i>[Signature]</i>	
DOUGLAS M. ISBELL, COUNTY ENGINEER	
RCE# 18634	EXP. 06/2007

SAN DIEGO COUNTY DESIGN STANDARD

GRADING OF SLOPES

REVISION	APPROVED	DATE
DRAWING NUMBER		DS-10

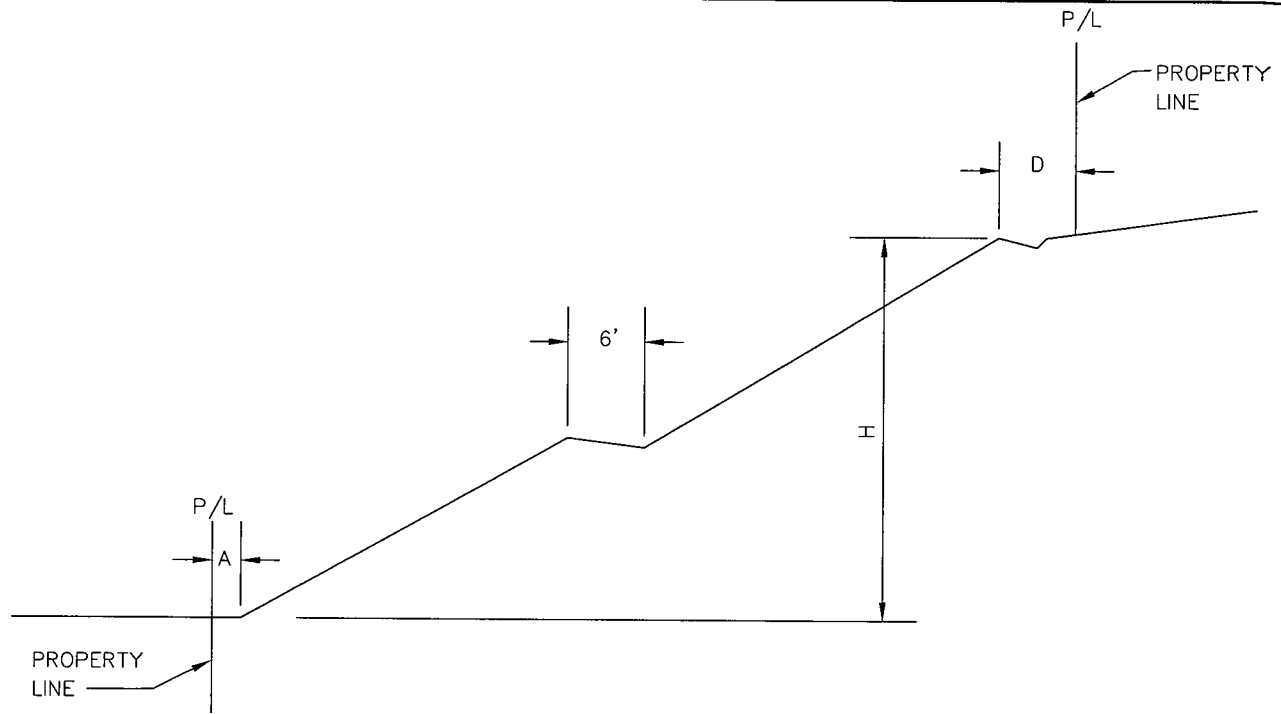

PROPERTY LINE SETBACKS

NO SCALE

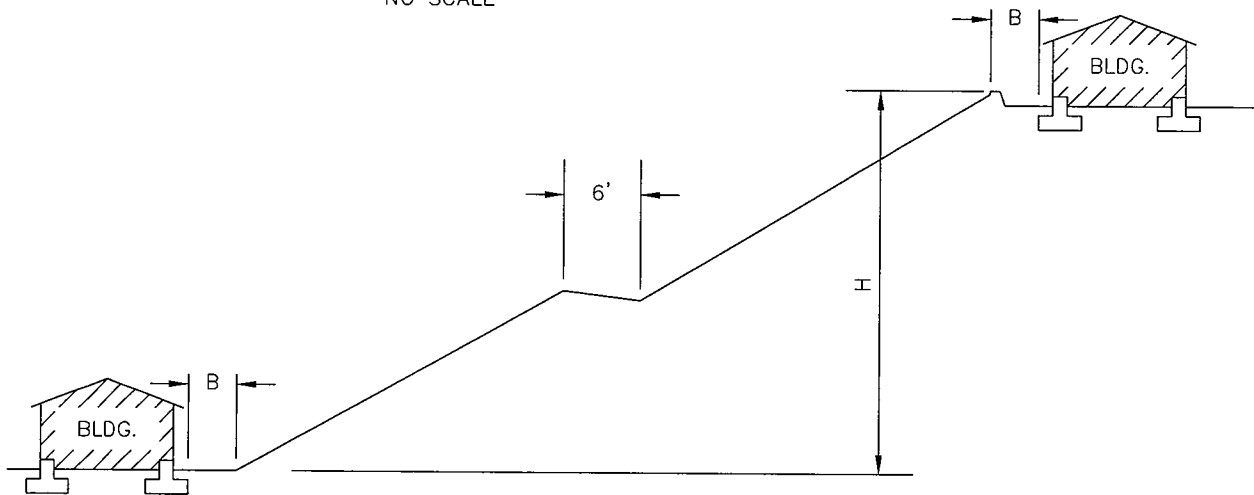

BUILDING SETBACKS

NO SCALE

REQUIRED SETBACKS			
H FEET	A	B	D
0-15	1'-6"	5'	3'
15-30	3'	5'	5'
OVER 30	5'	5'	5'

NOTES:

- A = DISTANCE FROM TOE OF SLOPE TO PROPERTY LINE.
- B = DISTANCE FROM EDGE OF FOUNDATION TO TOE OR TOP OF SLOPE.
- D = DISTANCE FROM TOP OF SLOPE TO PROPERTY LINE.
- H = TOTAL SLOPE HEIGHT MEASURED VERTICALLY.

DRAWN BY: <u>SS</u>	CHECKED BY: <u>LMC</u>	SAN DIEGO COUNTY DESIGN STANDARD	REVISION	APPROVED	DATE
RECOMMENDED BY: <u>JEFF S. MOODY</u>					
APPROVED BY: <u>[Signature]</u>		REQUIRED SETBACKS			
DOUGLAS M. ISBELL, COUNTY ENGINEER					
RCE# <u>18634</u> EXP. <u>06/2007</u>			DRAWING NUMBER DS-11		

SYMBOLS

* Established in accordance with
S.D. County Code, Div.5 of Title 7

LINES

Street Centerline (C) *	RS XXXX-X
Stage Construction Line	_____
Intersecting Roads & Streets	2 Per Inch
Right of Way Line	R/W
Equation or Radius Line
Offset Tie	-----
Grade Lines on Profiles	2% VC -1%
Original Ground on Profiles	-----
Slope Limit Lines	Toe of fill Top of cut
Existing Edge of Pavement	-----

UTILITIES

Gas Line	G
Water Line	W
Electric Line	E
Telephone Line	T
Sewer Line	S
Utility Manhole	O

STRUCTURAL SECTIONS

Portland Cement Concrete	[Symbol]
Asphalt Concrete (existing)	[Symbol]
Asphalt Concrete Surfacing	[Symbol]
Base Material	Label Class & Thickness
Original Ground	[Symbol]

MISCELLANEOUS SYMBOLS

Contracted Line (not to scale)	[Symbol]
Limit Arrows	[Symbol]
Project Work Limit	[Symbol]
Cutting Plane	[Symbol]

LAND LINES

Township Lines	Label
Section Lines	Label
Grand Line (Rancho Boundary or Indian Reservation)	Label
Subdivision Boundary Line	Label
City/County Boundary Line	County
Property Line	City
Lot Line	-----
Easement Line	-----

CADASTRAL SYMBOLS

POINTS

BC & EC	[Symbol]
PI or Angle PT	[Symbol]
C Monument	[Symbol]
Bench Mark	[Symbol]

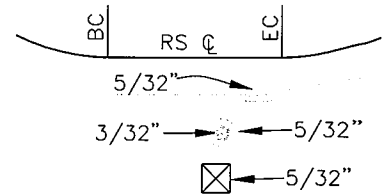

NEW CONSTRUCTION

Pavement Edge & Shoulders	[Symbol]
AC Dike (Label Type)	[Symbol]
Curb & Gutter (Label)	[Symbol]
Downdrain, AC Spillway	[Symbol]
Drop Inlet	[Symbol]
Box Culvert	[Symbol]
Headwall, Standard	[Symbol]
Headwall "L" Type	[Symbol]
Headwall & Wingwall	[Symbol]
Culvert	[Symbol]
Metal Beam Guard Rail	[Symbol]
Driveway Aprons AC	[Symbol]
Utility Duct (Label)	[Symbol]
Driveway Aprons PCC	[Symbol]
Concrete Cross Gutter	[Symbol]
Sidewalk (PCC)	[Symbol]
Retaining Wall (Label Type)	[Symbol]
Fence (Label Type)	[Symbol]
Ditch, Lined	[Symbol]
Ditch, Unlined	[Symbol]
Bridge	[Symbol]

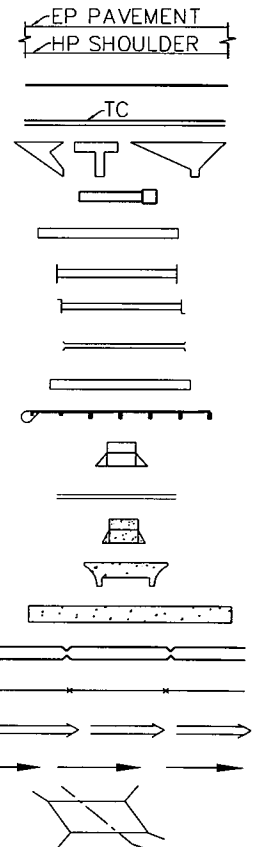

Refer to Regional Standard Drawings (RSD) and San Diego County Design Standards (SDCDS) for Construction Details.

SECTION LINES

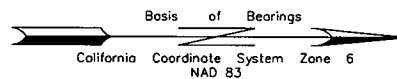
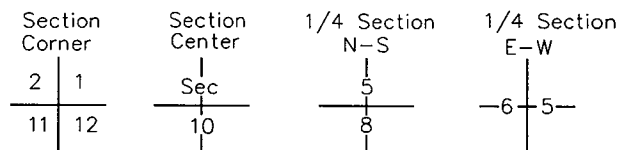

DRAWN BY: SS	CHECKED BY: LMC	SAN DIEGO COUNTY DESIGN STANDARD	REVISION	APPROVED	DATE
RECOMMENDED BY: JEFF S. MOODY					
APPROVED BY: <i>[Signature]</i>		CONSTRUCTION PLAN SYMBOLS			
DOUGLAS M. ISBELL, COUNTY ENGINEER					
RCE# 18634 EXP. 06/2007			DRAWING NUMBER DS-12		

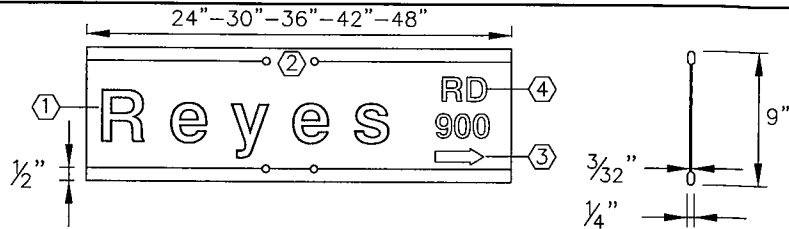
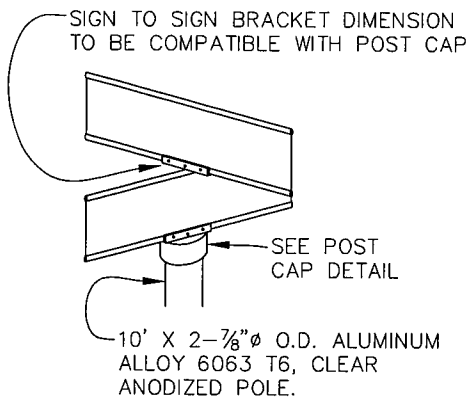

TYPICAL STREET NAME LAYOUT
NO SCALE

TYPICAL LAYOUT OF LEGEND AND BORDER ON VARIABLE LENGTH SIGN BLADE OF EXTRUDED ALUMINUM WITH REVERSE SCREENED REFLECTIVE SHEETING ENGINEERING GRADE. WHITE LETTERS & BORDER ON GREEN BACKGROUND.

- ① 5" UPPERCASE AND 3-3/4" LOWERCASE LETTERING.
- ② TWO 11/32" HOLES 4-1/16" APART CENTERED ON TOP AND BOTTOM EDGE OF BLADE TO MATCH HOLES IN SIGN BRACKET ASSEMBLIES.
- ③ 2" X 2-3/4" ARROW.
- ④ 2" UPPERCASE LETTERING.

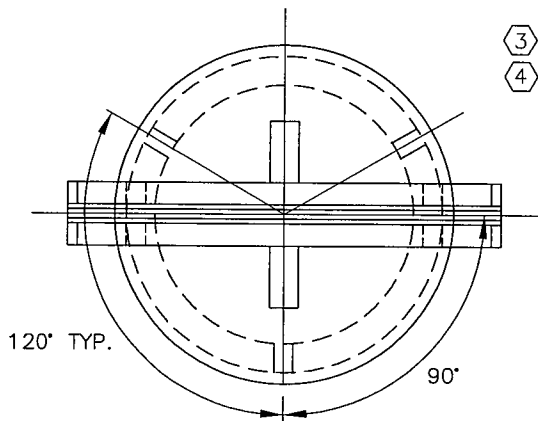

POST CAP DETAIL
NO SCALE

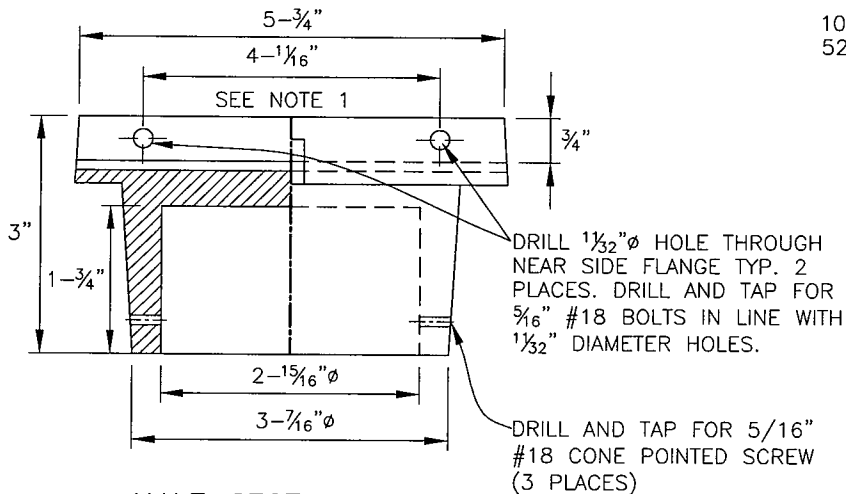

HALF-SECTION DETAIL
NO SCALE

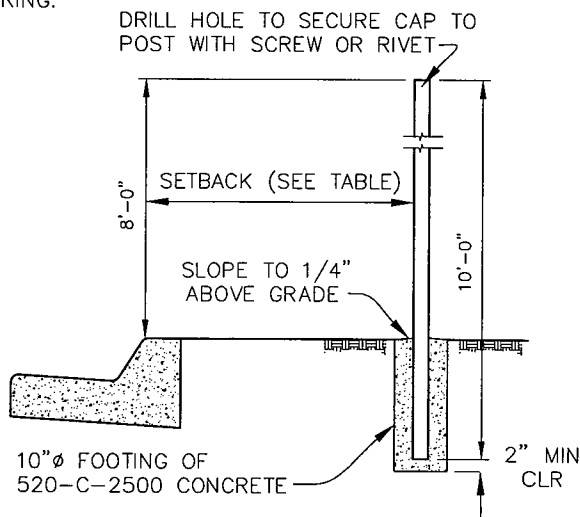

C & SW	SW	SETBACK
CONTIGUOUS	< or = 6'	SW WIDTH
CONTIGUOUS	> 6'	2'-0"
SEPARATE	----	2'-0"

CURB (C), SIDEWALK (SW), DIAMETER (Ø)

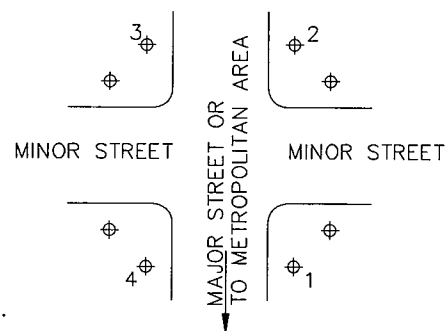

STREET NAME SIGN LOCATION

NUMBER INDICATES PRIORITY OF LOCATION SELECTION

NOTES:

1. 4 11/16" SPACING SHALL MATCH THE HOLES IN THE EXTRUDED BLADES.
2. BRACKET TO BE DIE CAST ALUMINUM.
3. ALL ATTACHING SCREWS SHALL BE VANDAL PROOF TYPE.

DRAWN BY: SS	CHECKED BY: JMC
RECOMMENDED BY: JEFF S. MOODY	
APPROVED BY: <i>D. M. Isbell</i>	
DOUGLAS M. ISBELL, COUNTY ENGINEER	
RCE# 18634	EXP. 06/2007

SAN DIEGO COUNTY DESIGN STANDARD

STREET NAME SIGN

REVISION	APPROVED	DATE
DRAWING NUMBER		DS-13

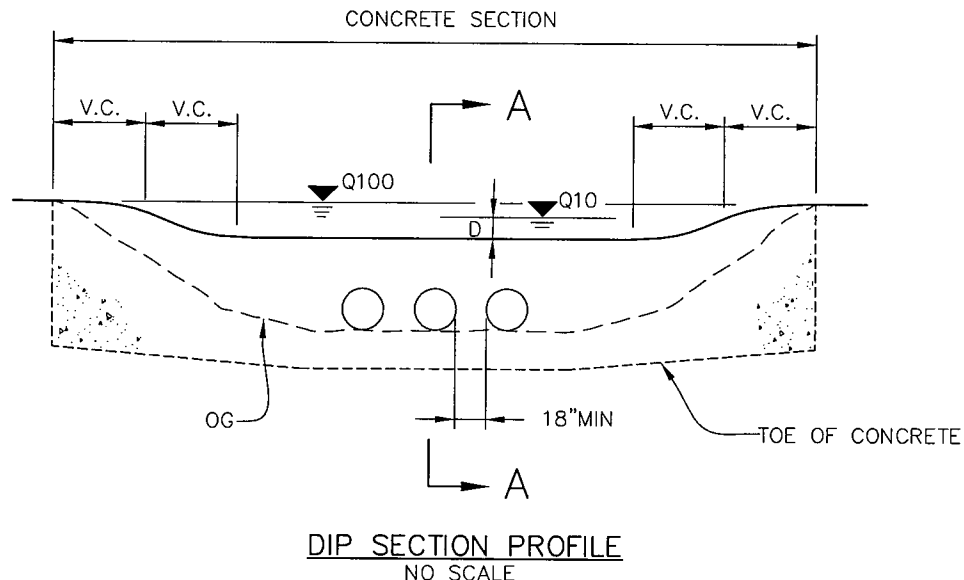
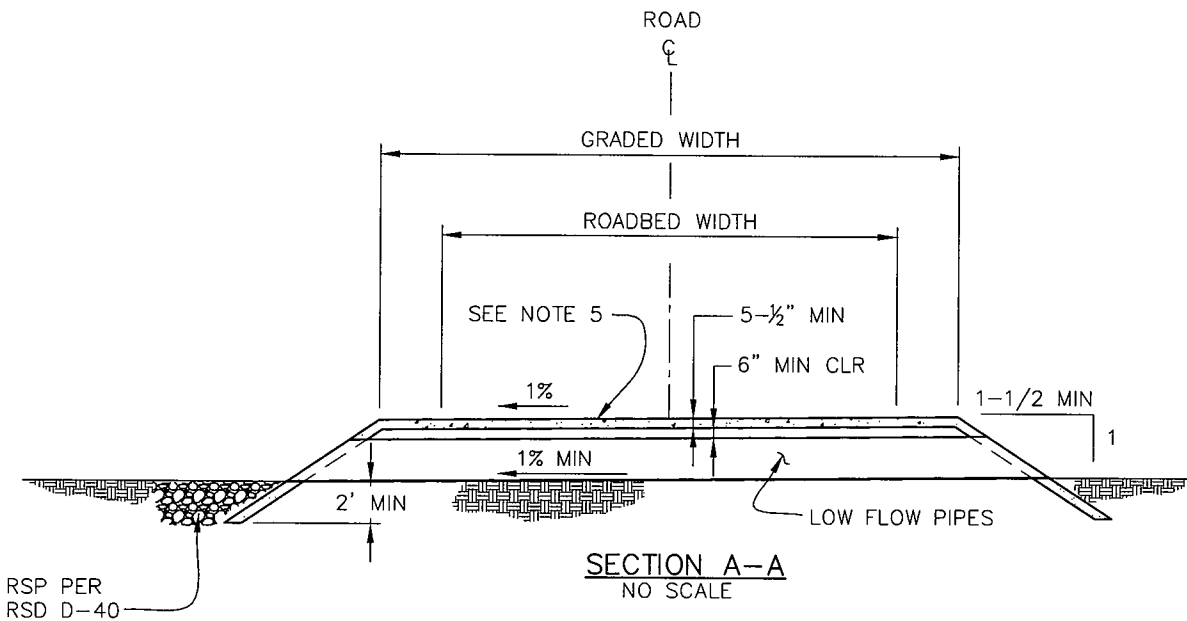

NOTES:

1. DIP SECTIONS SHALL CONFORM TO SECTION 5.11, "DRAINAGE IMPROVEMENTS" OF THE COUNTY OF SAN DIEGO PUBLIC ROAD STANDARDS.
2. THE MAXIMUM WATER DEPTH, BASED ON A Q10 FREQUENCY STORM, SHALL BE 10". THE DEPTH (D) IN FEET MULTIPLIED BY THE VELOCITY (V) IN FEET PER SECOND SHALL NOT EXCEED 6 ($D \times V \leq 6$).
3. VERTICAL CURVES SHALL BE DESIGNED IN ACCORDANCE WITH THE MOST RECENT EDITION OF THE CALTRANS HIGHWAY DESIGN MANUAL.
4. LOW FLOW PIPES (18" MINIMUM DIAMETER) MAY BE OMITTED IF THE CONDITIONS OF NOTE 2 CAN BE SATISFIED WITHOUT THEIR USE.
5. STRUCTURE TO BE 560-C-3250 CONCRETE WITH 6" X 6" 10 GA WWF

DRAWN BY: <u>SS</u>	CHECKED BY: <u>JMC</u>	SAN DIEGO COUNTY DESIGN STANDARD	REVISION	APPROVED	DATE
RECOMMENDED BY: <u>JEFF S. MOODY</u>					
APPROVED BY:		DIP SECTION (PRIVATE STREET)			
DOUGLAS M. ISBELL, COUNTY ENGINEER					
RCE# <u>18634</u> EXP. <u>06/2007</u>			DRAWING NUMBER DS-14		

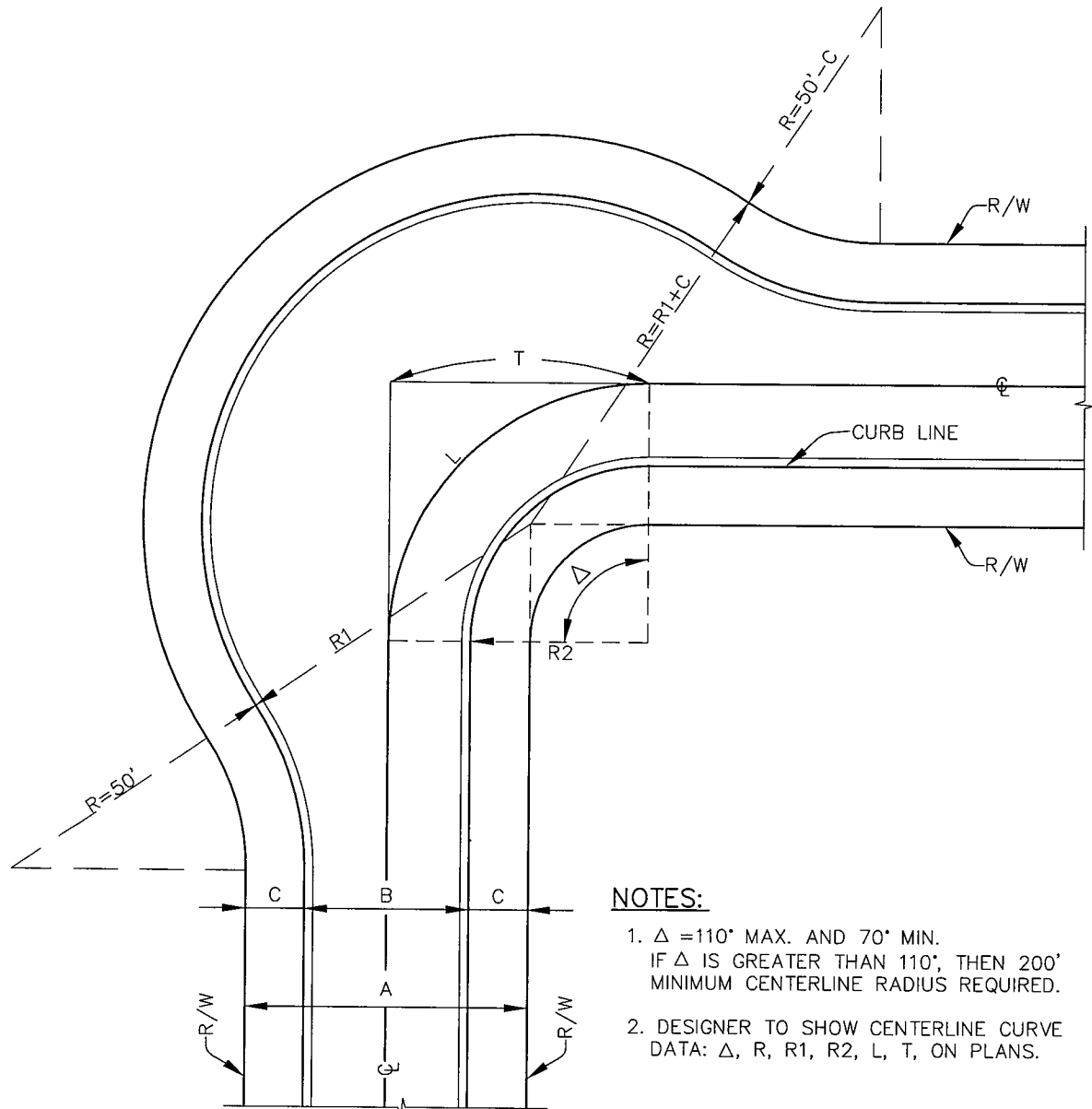

NOTES:

- $\Delta = 110^\circ$ MAX. AND 70° MIN.
IF Δ IS GREATER THAN 110° , THEN 200' MINIMUM CENTERLINE RADIUS REQUIRED.
- DESIGNER TO SHOW CENTERLINE CURVE DATA: Δ , R , $R1$, $R2$, L , T , ON PLANS.

PLAN
NO SCALE

A (R/W)	B	R1*	R2*	C*
72'	52'	80'	40'	10'
60'	40'	68'	30'	10'
56'	36'	64'	30'	10'
52'	32'	60'	30'	10'
48'	28'	56'	30'	10'

* DIMENSIONS SHOWN ARE MINIMUMS

DRAWN BY: SS CHECKED BY: LMC
 RECOMMENDED BY: JEFF S. MOODY
 APPROVED BY: *DM*
 DOUGLAS M. ISBELL, COUNTY ENGINEER
 RCE# 18634 EXP. 06/2007

SAN DIEGO COUNTY DESIGN STANDARD

STREET KNUCKLE

REVISION	APPROVED	DATE

DRAWING NUMBER **DS-15**

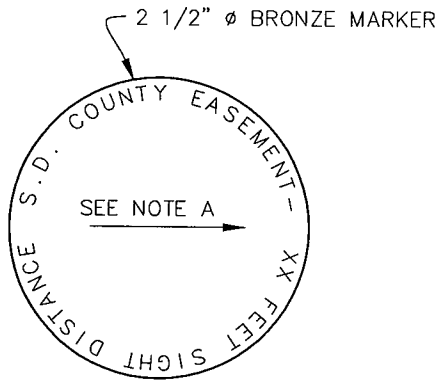

BRONZE MARKER
NO SCALE

NOTE A:
ROTATE ARROW TO INDICATE
LOCATION OF TARGET POINT. SHOW
SIGHT DISTANCE (XX) IN FEET

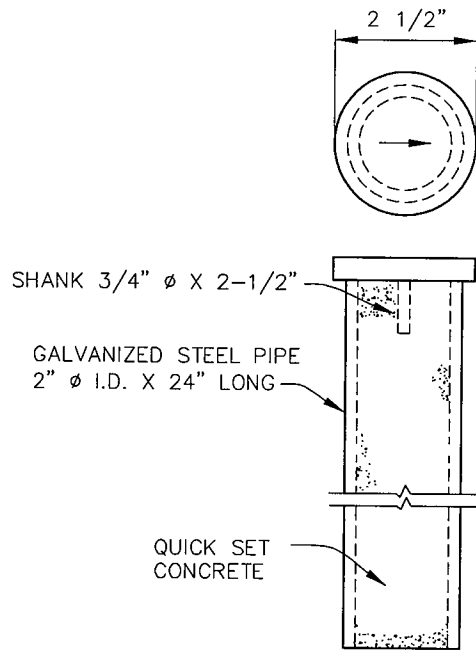

CASE 2 MARKER
NO SCALE

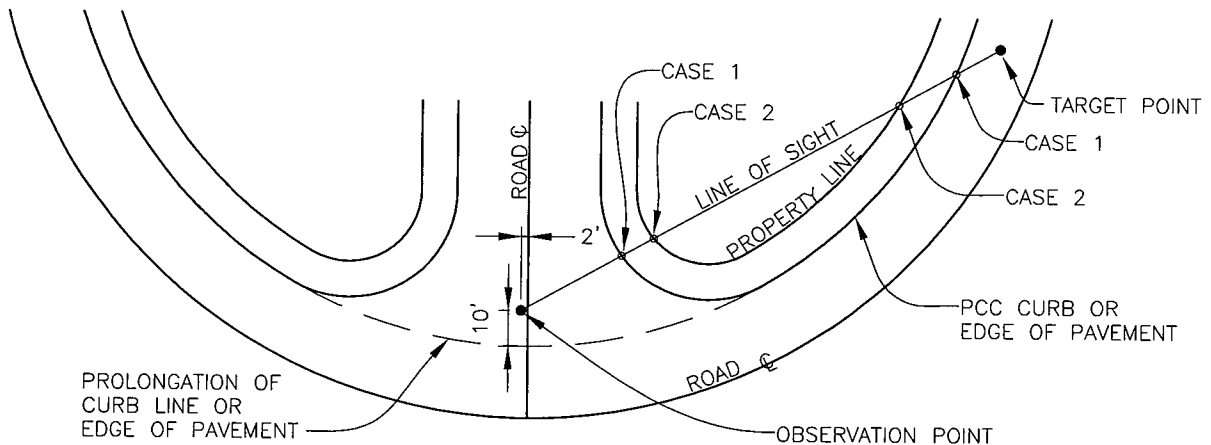

INTERSECTION DETAIL
NO SCALE

NOTES:

CASE 1: BRONZE MARKER TO BE SET IN PCC CURB WHERE LINE-OF-SIGHT INTERSECTS CURB.

CASE 2: IF NO PCC CURB, SET BRONZE MARKER IN CONCRETE IN 2" ϕ X 24" LONG GALVANIZED STEEL PIPE AT THE INTERSECTION OF THE LINE-OF-SIGHT AND PROPERTY LINE.

CLEAR SPACE EASEMENTS FOR SIGHT DISTANCE, WHERE SPECIFIED ON PLANS, SHALL BE DESIGNATED BY A BRONZE MARKER ACCORDING TO CASE 1 OR CASE 2 ABOVE.

DRAWN BY: <u>SS</u>	CHECKED BY: <u>LMC</u>	SAN DIEGO COUNTY DESIGN STANDARD	REVISION	APPROVED	DATE
RECOMMENDED BY: <u>JEFF S. MOODY</u>					
APPROVED BY: <u><i>D. M. Isbell</i></u>		CLEAR SPACE EASEMENT MARKERS			
DOUGLAS M. ISBELL, COUNTY ENGINEER			DRAWING NUMBER	DS-16	
RCE# <u>18634</u>	EXP. <u>06/2007</u>				

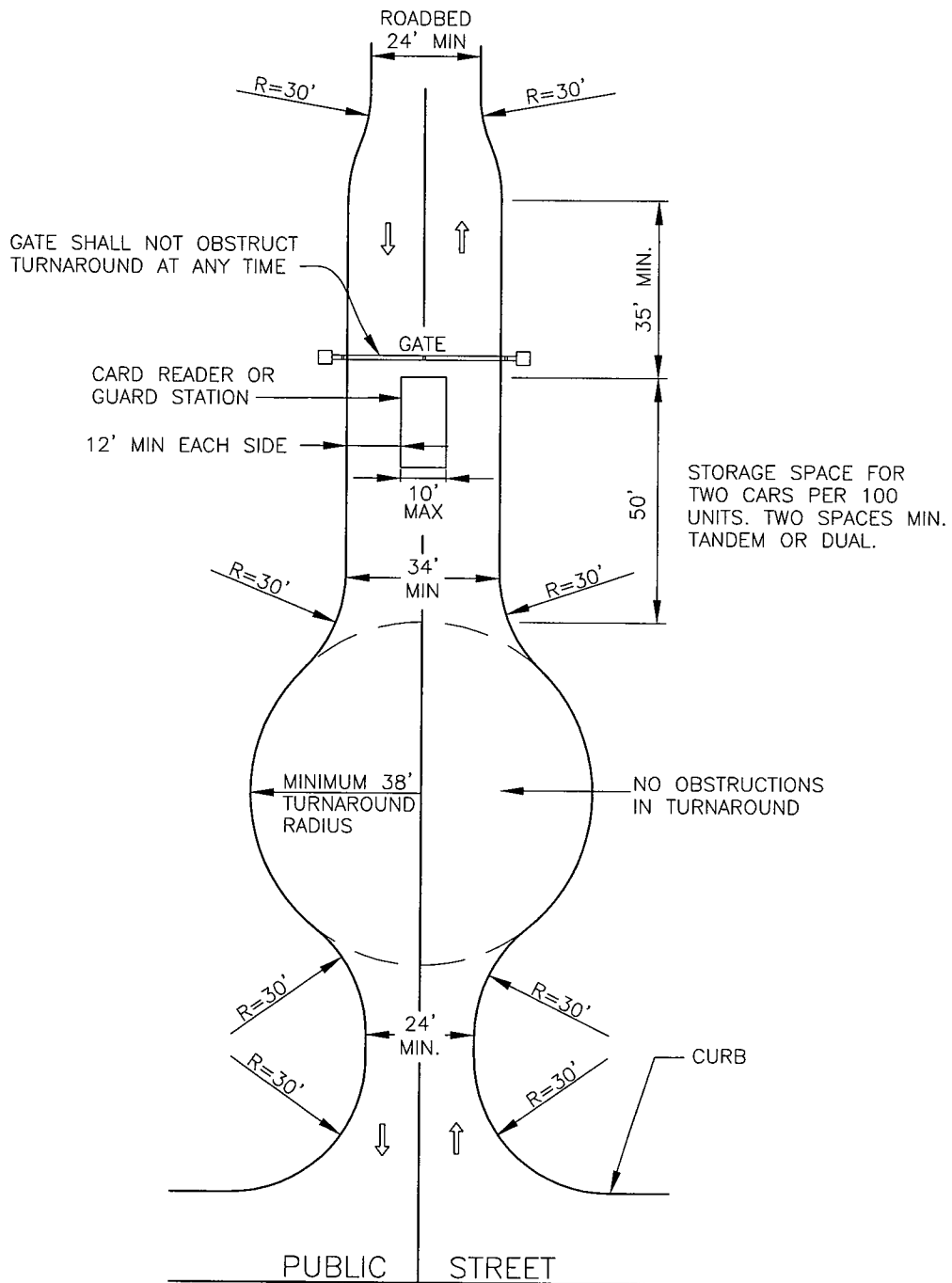

GATED DRIVEWAY ENTRANCE
NO SCALE

DRAWN BY: SS	CHECKED BY: LMC
RECOMMENDED BY: JEFF S. MOODY	
APPROVED BY: <i>D. M. Isbell</i>	
DOUGLAS M. ISBELL, COUNTY ENGINEER	
RCE# 18634	EXP. 06/2007

SAN DIEGO COUNTY DESIGN STANDARD

GATED DRIVEWAY ENTRANCE
TYPE I

REVISION	APPROVED	DATE

DRAWING NUMBER DS-17

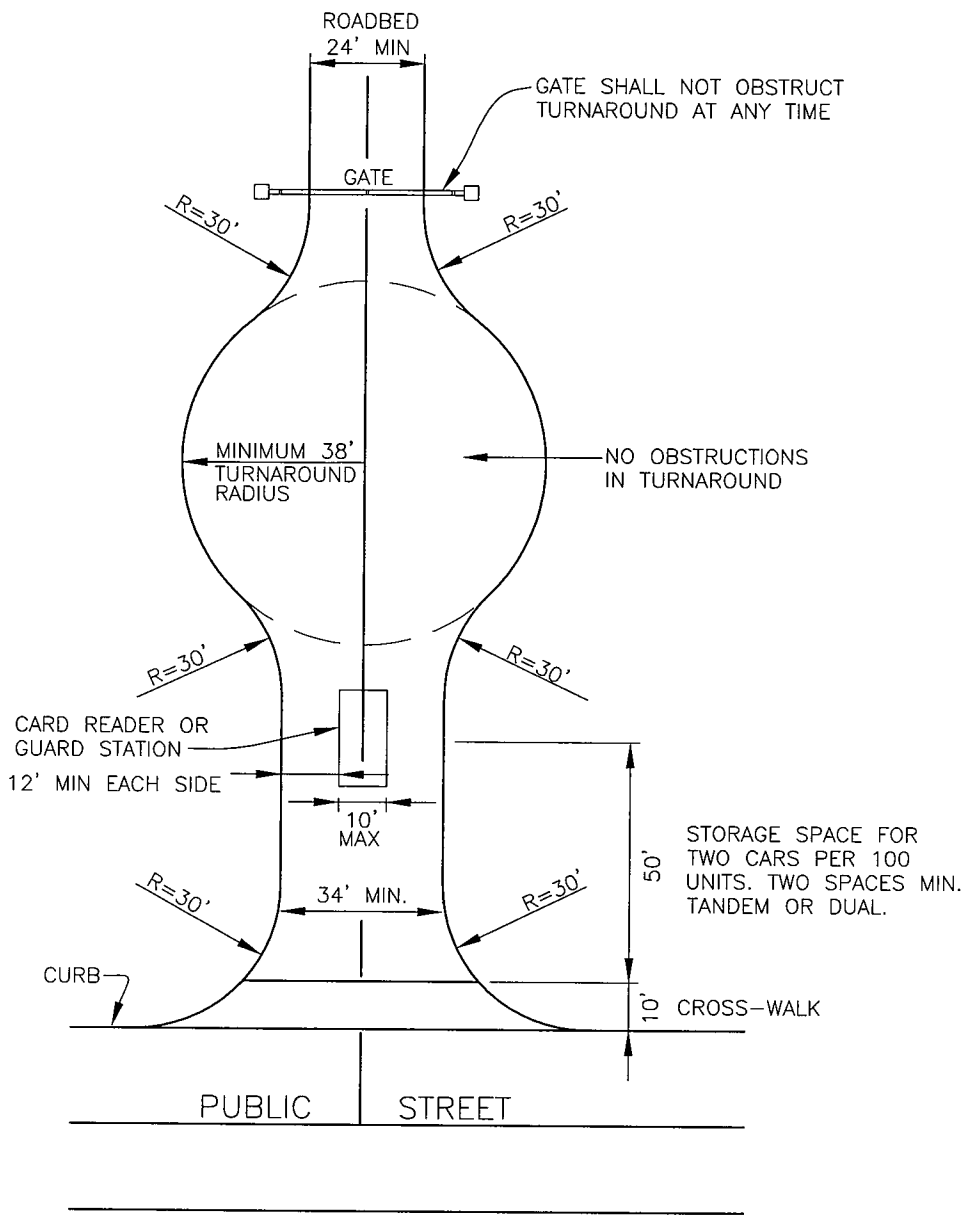

GATED DRIVEWAY ENTRANCE

NO SCALE

DRAWN BY: SS CHECKED BY: LMC

RECOMMENDED BY: JEFF S. MOODY

APPROVED BY: D. M. Isbell

DOUGLAS M. ISBELL, COUNTY ENGINEER

RCE# 18634 EXP. 06/2007

SAN DIEGO COUNTY DESIGN STANDARD

GATED DRIVEWAY ENTRANCE
TYPE II

REVISION	APPROVED	DATE

DRAWING
NUMBER DS-18

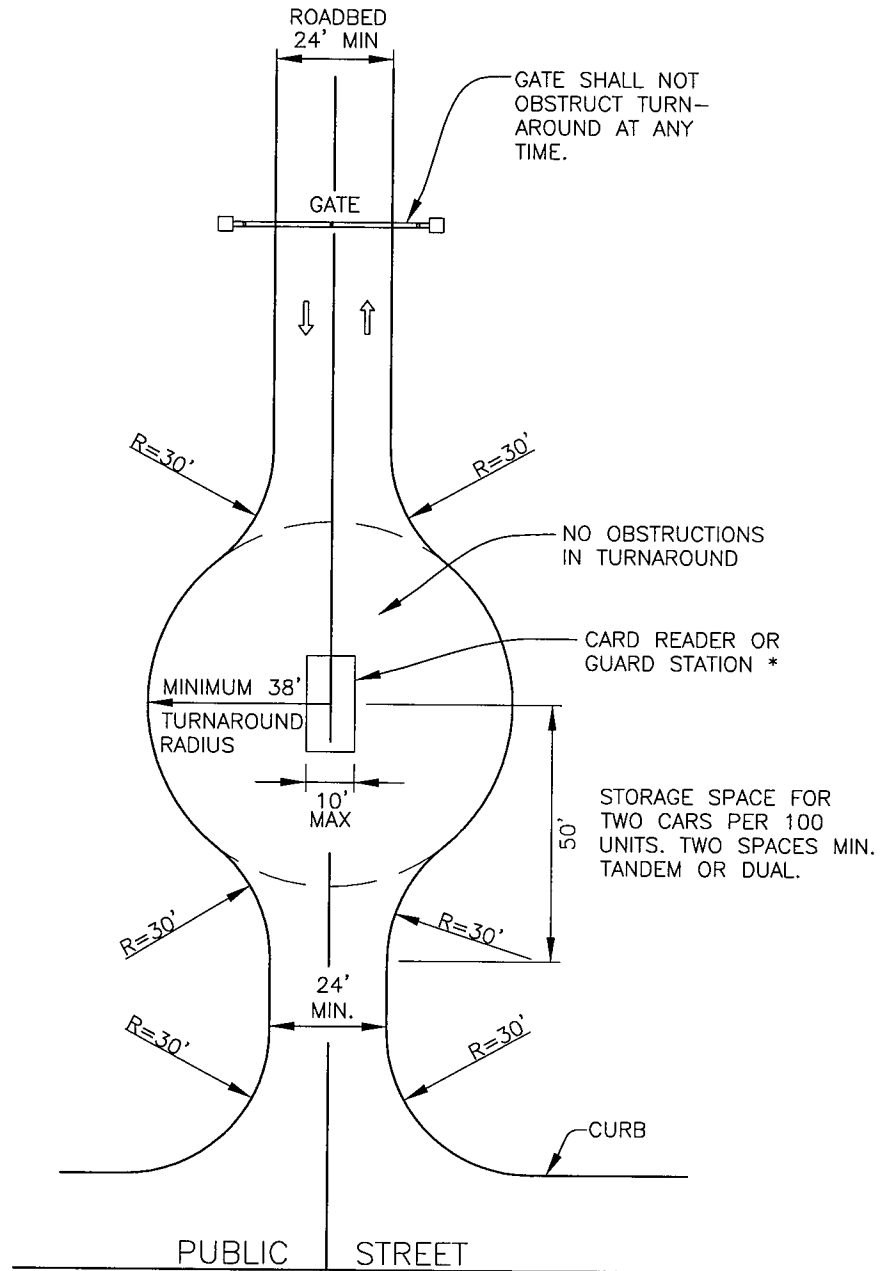

GATED DRIVEWAY ENTRANCE

NO SCALE

* CARD READER OR GUARD STATION MUST PROVIDE SUFFICIENT ROOM FOR AN EMERGENCY VEHICLE TO TURN AROUND.

DRAWN BY: SS CHECKED BY: LMC

RECOMMENDED BY: JEFF S. MOODY

APPROVED BY: *D. M. Isbell*

DOUGLAS M. ISBELL, COUNTY ENGINEER

RCE# 18634 EXP. 06/2007

SAN DIEGO COUNTY DESIGN STANDARD

GATED DRIVEWAY ENTRANCE
TYPE III

REVISION	APPROVED	DATE

DRAWING NUMBER **DS-19**

SIGHT DISTANCE REQUIREMENTS AT ALL INTERSECTIONS SHALL CONFORM TO THE INTERSECTIONAL SIGHT DISTANCE CRITERIA AS PROVIDED BELOW

REQUIRED SIGHT DISTANCE (FT) = ROAD "A" DESIGN SPEED (MPH) X 10FT/MPH

REFERENCE: COUNTY OF SAN DIEGO PUBLIC ROAD STANDARDS (TABLE # 5, PAGE 34)	
DESIGN SPEED MPH	MINIMUM CORNER INTERSECTION SIGHT DISTANCE (FEET)*
60	600
50	500
40	400
30	300
20	200

*CORNER SIGHT DISTANCE IS MEASURED FROM AN OBSERVATION POINT 2 FEET RIGHT OF ROAD "B" CENTERLINE AND 10 FEET BACK FROM ROAD "A" EDGE OF PAVEMENT MEASURED FROM A HEIGHT OF 3.5 FEET TO AN OBJECT HEIGHT OF 4.25 FEET

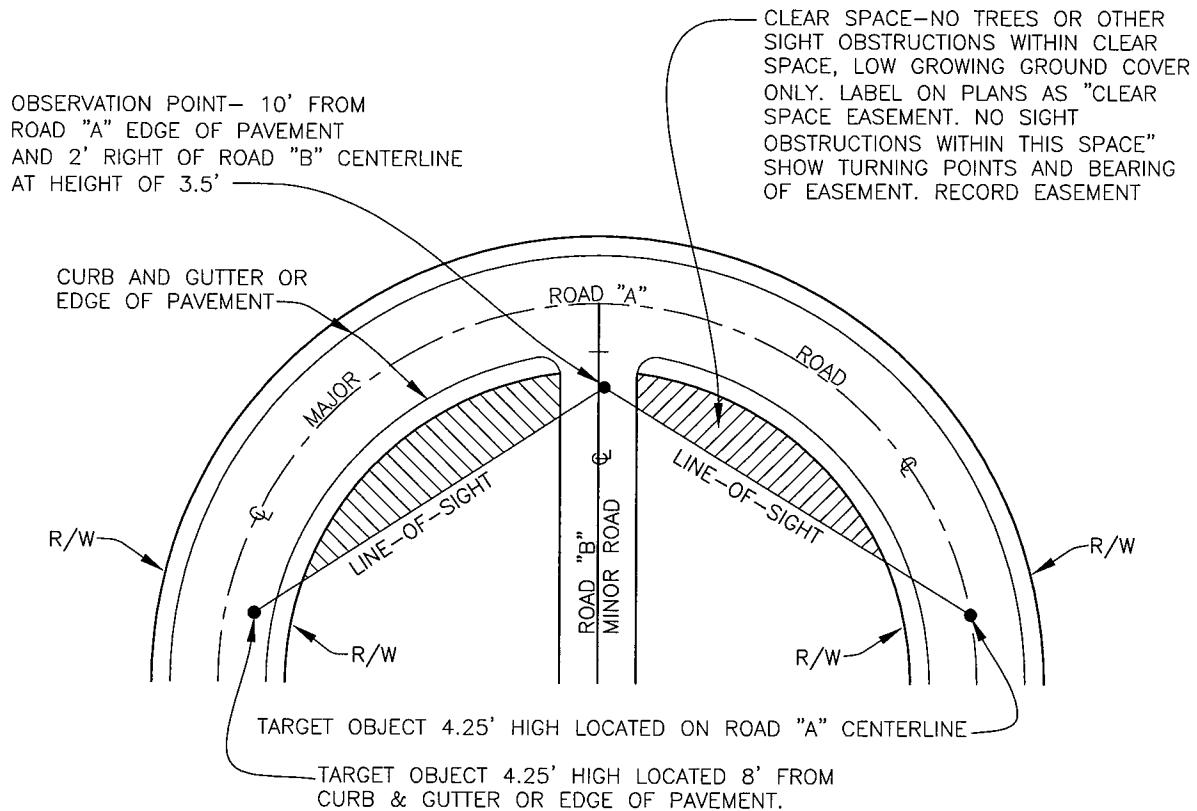

INTERSECTION SIGHT DISTANCE
NO SCALE

NOTE: THE REQUIRED SIGHT DISTANCE APPLIES TO BOTH HORIZONTAL AND VERTICAL OBSTRUCTIONS.

DRAWN BY: <u>SS</u>	CHECKED BY: <u>JMC</u>	SAN DIEGO COUNTY DESIGN STANDARD	REVISION	APPROVED	DATE
RECOMMENDED BY: <u>JEFF S. MOODY</u>					
APPROVED BY: <u>D. M. Isbell</u>		CLEAR SPACE EASEMENT TYPE A			
DOUGLAS M. ISBELL, COUNTY ENGINEER					
RCE# <u>18634</u> EXP. <u>06/2007</u>			DRAWING NUMBER DS-20A		

REFERENCE: COUNTY OF SAN DIEGO PUBLIC ROAD STANDARDS (TABLE # 5, PAGE 34)	
DESIGN SPEED MPH	MINIMUM CORNER INTERSECTION SIGHT DISTANCE (FEET)*
60	600
50	500
40	400
30	300
20	200

*CORNER SIGHT DISTANCE IS MEASURED FROM AN OBSERVATION POINT 2 FEET RIGHT OF ROAD "B" CENTERLINE AND 10 FEET BACK FROM ROAD "A" EDGE OF PAVEMENT MEASURED FROM A HEIGHT OF 3.5' TO AN OBJECT HEIGHT OF 4.25 FEET

CLEAR SPACE EASEMENTS—NO TREES OR OTHER SIGHT OBSTRUCTIONS WITHIN CLEAR SPACE, LOW GROWING GROUND COVER ONLY. LABEL ON PLANS AS "CLEAR SPACE EASEMENT. NO SIGHT OBSTRUCTIONS WITHIN THIS SPACE." SHOW TURNING POINT AND BEARING OF EASEMENT. RECORD EASEMENT

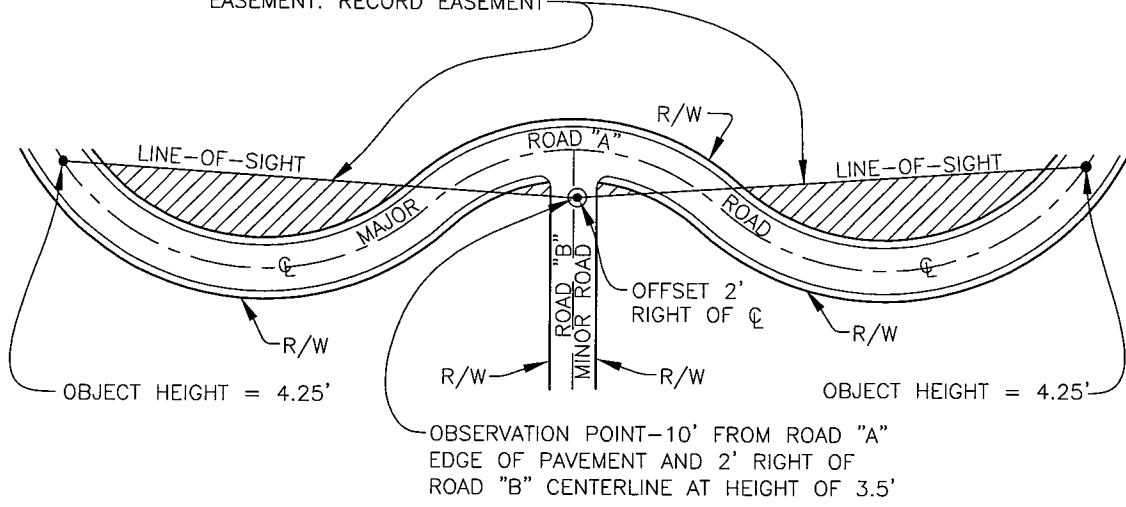

INTERSECTION SIGHT DISTANCE
NO SCALE

NOTE: THE REQUIRED SIGHT DISTANCE APPLIES TO BOTH HORIZONTAL AND VERTICAL OBSTRUCTIONS

DRAWN BY: <u>SS</u>	CHECKED BY: <u>LMC</u>	SAN DIEGO COUNTY DESIGN STANDARD	REVISION	APPROVED	DATE
RECOMMENDED BY: <u>JEFF S. MOODY</u>					
APPROVED BY: <u>D. M. Isbell</u>		CLEAR SPACE EASEMENT TYPE B			
DOUGLAS M. ISBELL, COUNTY ENGINEER					
RCE# <u>18634</u>	EXP. <u>06/2007</u>		DRAWING NUMBER <u>DS-20B</u>		

MONOLITHIC CURB (H=6") IF SPECIFIED OR REQUIRED

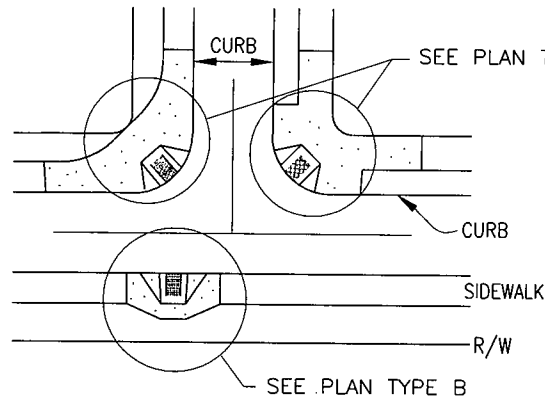
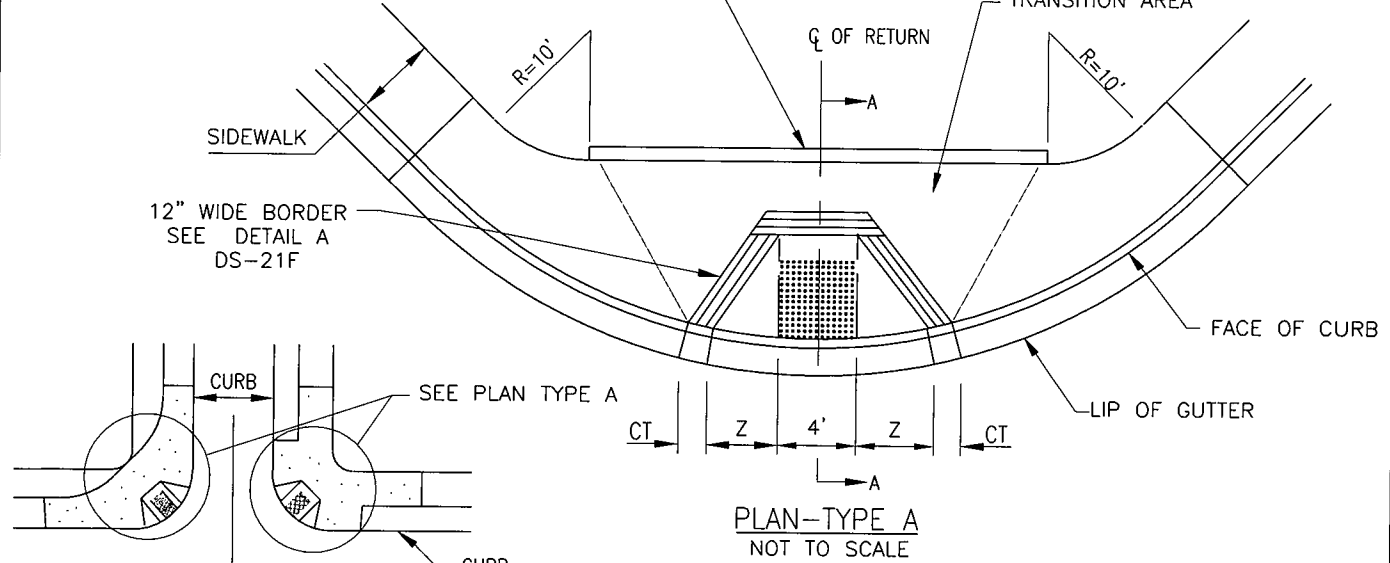

MONOLITHIC CURB (H=6") IF SPECIFIED OR REQUIRED

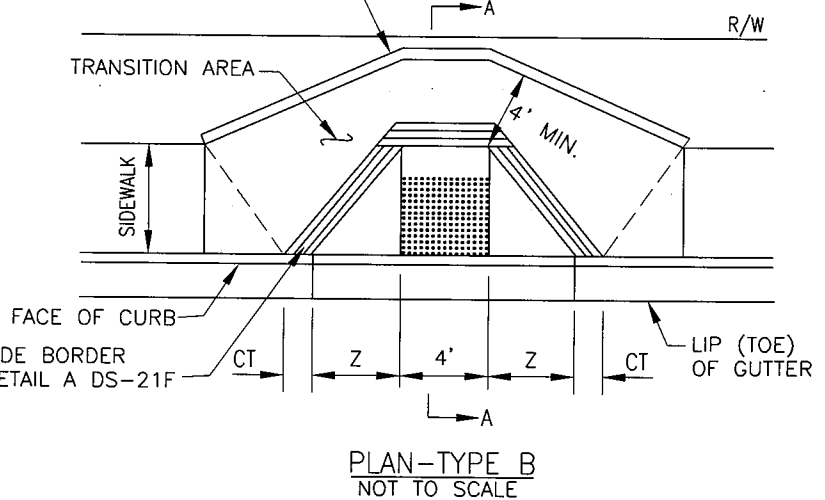
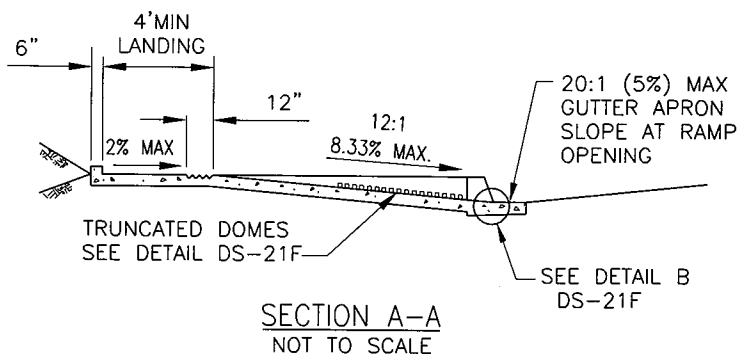
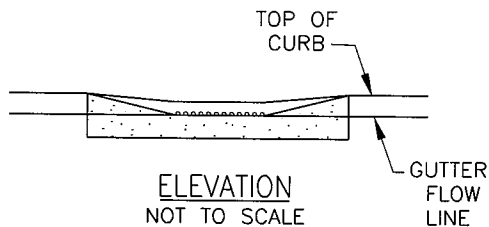

TABLE A			
X	Y	Z	CT
CURB HEIGHT	RAMP LENGTH (12:1)	SIDE SLOPE (10:1)	CURB TRANS.
1"	1'-0"	1'-6"	0'-0"
2"	2'-0"	1'-8"	0'-0"
3"	3'-0"	2'-6"	0'-0"
4"	4'-0"	3'-4"	0'-0"
5"	5'-0"	4'-2"	0'-0"
6"	6'-0"	5'-0"	0'-0"
7"	7'-0"	5'-0"	1'-0"
8"	8'-0"	5'-0"	2'-0"



NOTES:

1. SEE DRAWING DS-21E GENERAL NOTES FOR CURB RAMPS.
2. FOR TRUNCATED DOME DETAILS, SEE DRAWING DS-21F.

DRAWN BY: SS CHECKED BY: SMB
 RECOMMENDED BY: JEFF S. MOODY
 APPROVED BY: Mohamad
 MOHAMAD FAKHRIIDINE, COUNTY ENGINEER
 RCE# 44520 EXP. 03/31/08

SAN DIEGO COUNTY DESIGN STANDARD

**CURB RAMP - TYPES A & B
(NEW CONSTRUCTION)**

REVISION	APPROVED	DATE
DRAWING NUMBER		DS-21A

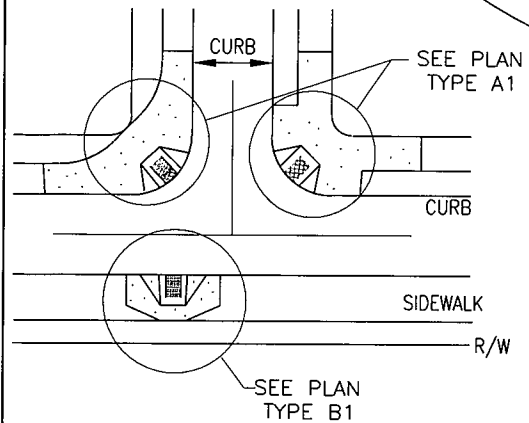
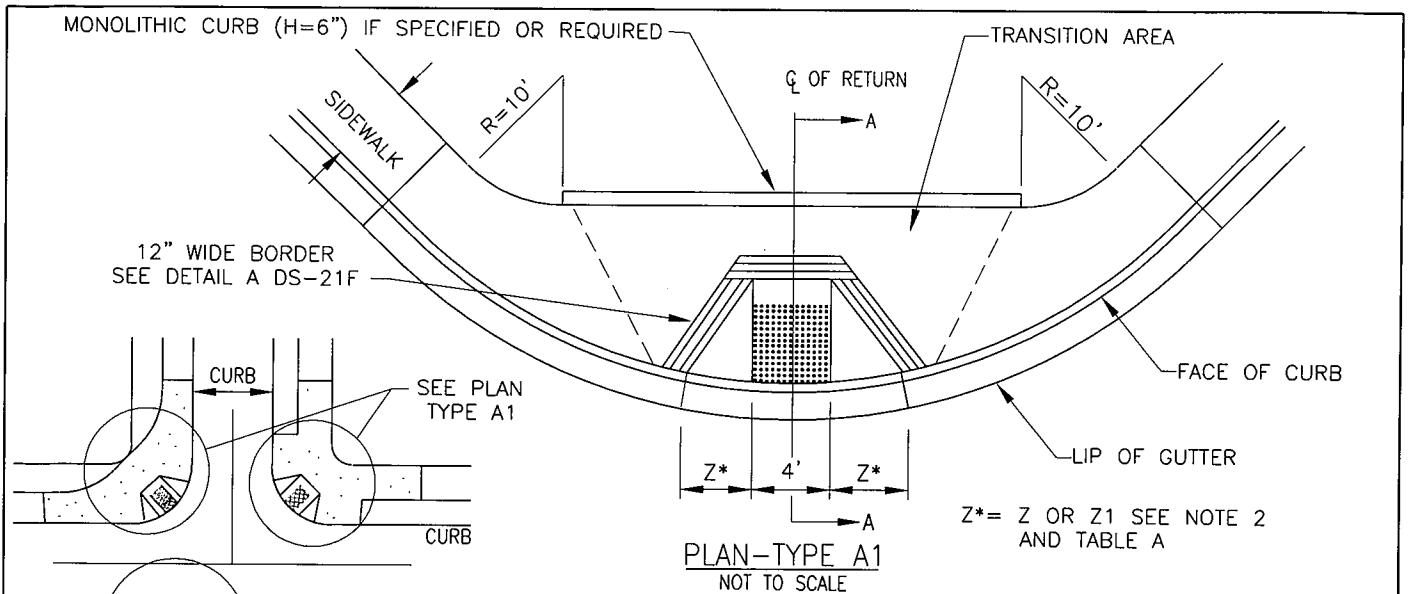
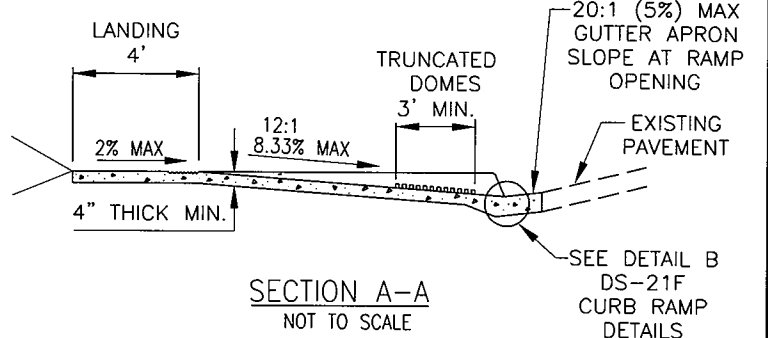
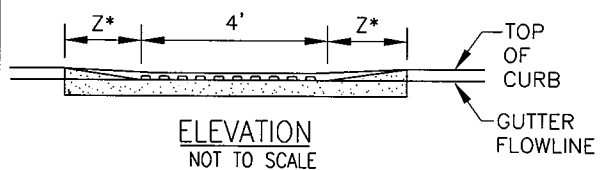
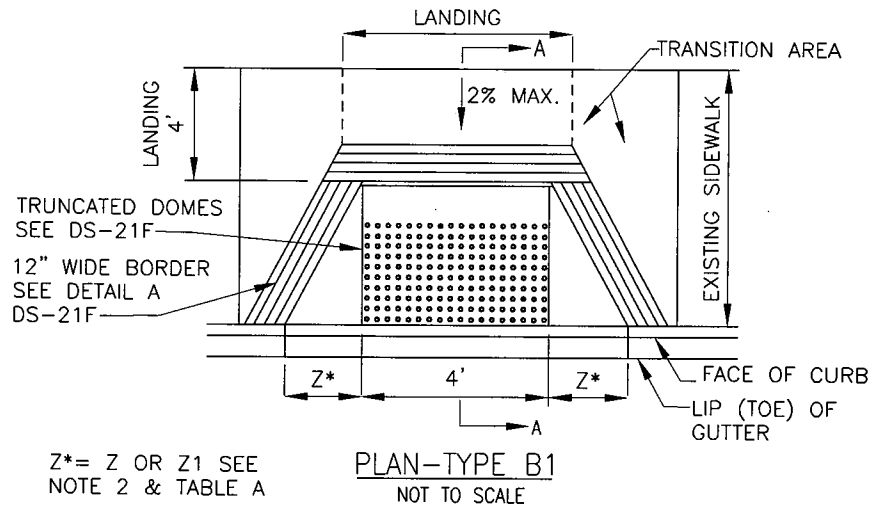

TABLE A			
X	Y	Z	Z1
CURB HEIGHT	RAMP LENGTH (12:1)	SIDE SLOPE (10:1)	SIDE SLOPE (12:1)
1"	1'-0"	1'-6"	1'-0"
2"	2'-0"	1'-8"	2'-0"
3"	3'-0"	2'-6"	3'-0"
4"	4'-0"	3'-4"	4'-0"
5"	5'-0"	4'-2"	5'-0"
6"	6'-0"	5'-0"	6'-0"
7"	7'-0"	5'-10"	7'-0"
8"	8'-0"	6'-8"	8'-0"



NOTES:

1. SEE DRAWING DS-21E GENERAL NOTES FOR CURB RAMPS.
2. TYPE A1 AND B1 CURB RAMP MAY BE USED AT LOCATIONS WITH EXISTING SIDEWALK BUT WHERE INADEQUATE R/W EXISTS TO CONSTRUCT A 4' DEEP LANDING. FOR THESE LOCATIONS A LANDING WITH LESS THAN 4' BUT AT LEAST 3' IS ACCEPTABLE PROVIDED THE SIDE SLOPES ARE REVISED TO 12:1 PER SIDE SLOPE Z1 IN TABLE A.
3. FOR TRUNCATED DOME DETAILS, SEE DRAWING DS-21F CURB RAMP DETAILS.

DRAWN BY: SS CHECKED BY: SMB
 RECOMMENDED BY: JEFF S. MOODY
 APPROVED BY: Mohamad
 MOHAMAD FAKHRIDDINE, COUNTY ENGINEER
 RCE# 44520 EXP. 03/31/08

SAN DIEGO COUNTY DESIGN STANDARD

CURB RAMP - TYPES A1 & B1
(FOR EXISTING SIDEWALK)

REVISION	APPROVED	DATE
DRAWING NUMBER		DS-21B

12" WIDE BORDER
SEE DETAIL A DS-21F

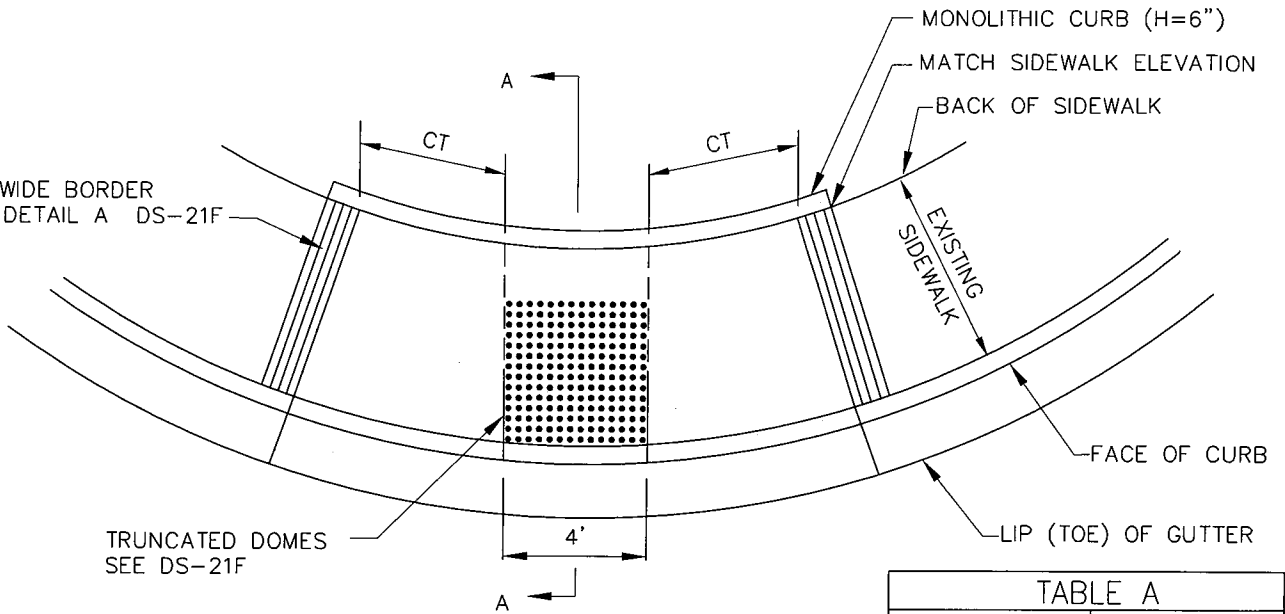

PLAN
NOT TO SCALE

X CURB HEIGHT	CT (12:1) CURB TRANSITION
4"	4'-0"
5"	5'-0"
6"	6'-0"
7"	7'-0"
8"	8'-0"
9"	9'-0"
10"	10'-0"
11"	11'-0"
12"	12'-0"
13"	13'-0"

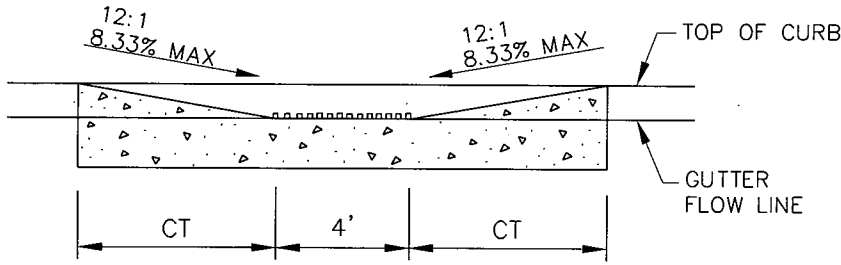

ELEVATION
NOT TO SCALE

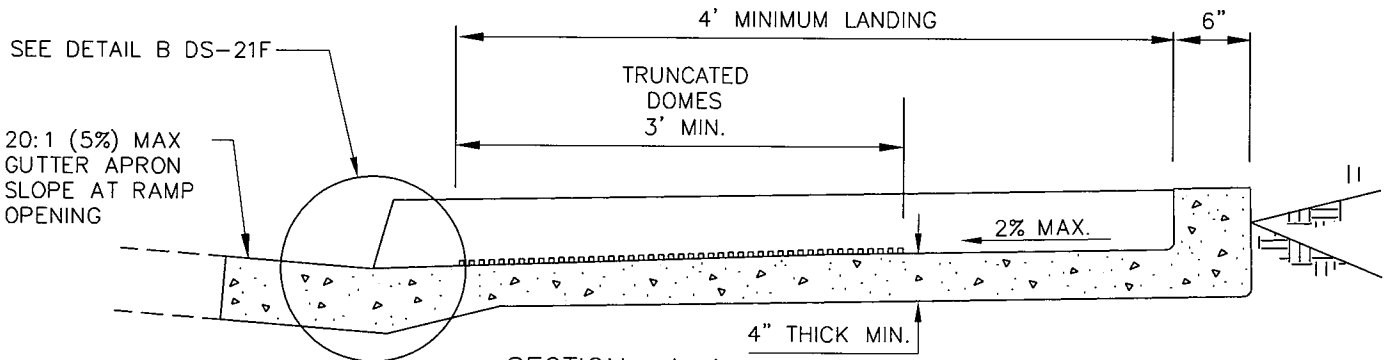

SECTION A-A
NOT TO SCALE

NOTES:

1. TYPE C RAMPS ARE ONLY TO BE USED TO MITIGATE EXISTING CONDITIONS WHERE INADEQUATE RIGHT OF WAY EXISTS TO USE DS-21B, AND ARE NOT TO BE USED FOR NEW CONSTRUCTION.
2. SEE DRAWING DS-21E GENERAL NOTES FOR CURB RAMPS.
3. FOR TRUNCATED DOME DETAILS, SEE DRAWING DS-21F CURB RAMP DETAILS
4. CT CURVE TRANSITION SLOPE SHALL BE 12:1 (8.33%) MAXIMUM. SEE TABLE A

DRAWN BY: <u>SS</u>	CHECKED BY: <u>SMB</u>
RECOMMENDED BY: <u>JEFF S. MOODY</u>	
APPROVED BY: <i>Mohamad</i>	
MOHAMAD FAKHRIDDINE, COUNTY ENGINEER	
RCE# <u>44520</u>	EXP. <u>03/31/08</u>

SAN DIEGO COUNTY DESIGN STANDARD

**CURB RAMP - TYPE C
(FOR EXISTING SIDEWALK)**

REVISION	APPROVED	DATE
DRAWING NUMBER	DS-21C	

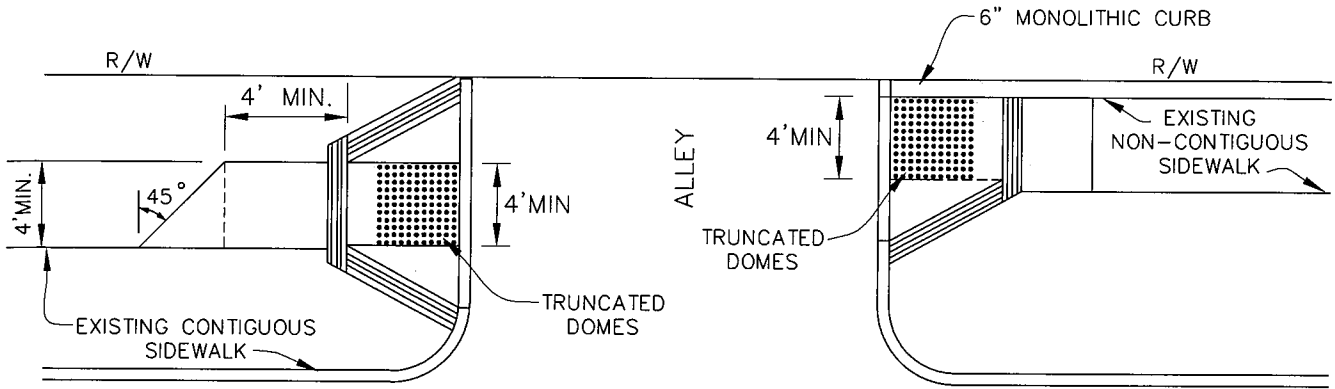

TYPICAL PLAN
NOT TO SCALE

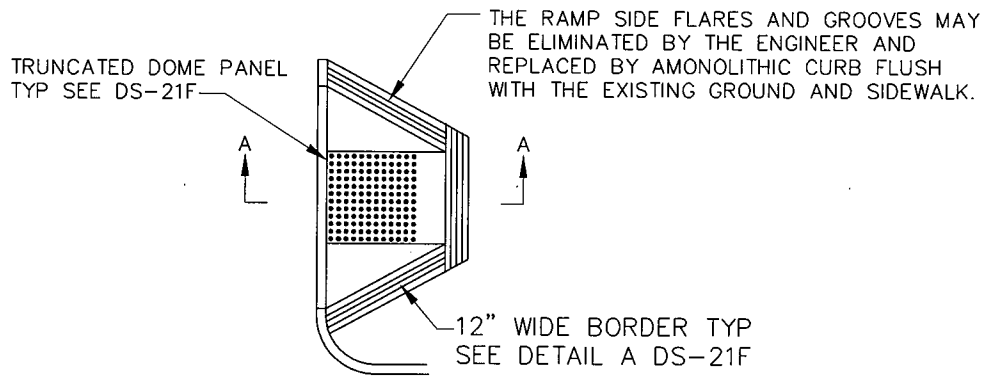

PLAN VIEW
NOT TO SCALE

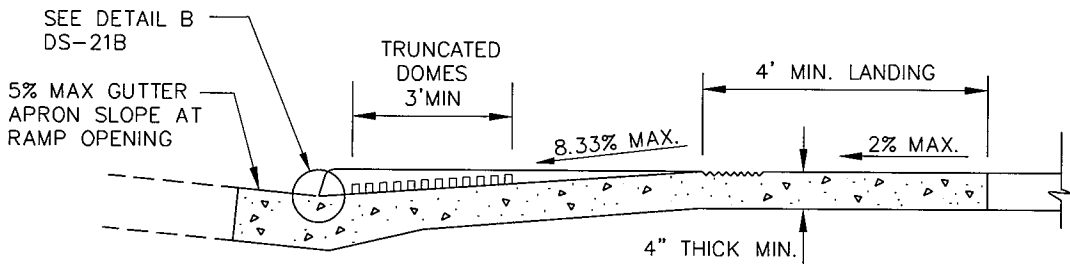

SECTION A - A
NOT TO SCALE

NOTES:

1. SEE DRAWING DS-21E GENERAL NOTES FOR CURB RAMPS
2. FOR TRUNCATED DOME DETAILS, SEE DS-21F CURB RAMP DETAILS.
3. TYPE D CURB RAMPS SHALL BE USED ONLY ON ALLEY STREETS

DRAWN BY: <u>SS</u> CHECKED BY: <u>SMB</u> RECOMMENDED BY: <u>JEFF S. MOODY</u> APPROVED BY: <u>Mohamad</u> MOHAMAD FAKHRRIDDINE, COUNTY ENGINEER RCE# <u>44520</u> EXP. <u>03/31/08</u>	SAN DIEGO COUNTY DESIGN STANDARD CURB RAMP - TYPE D	REVISION APPROVED DATE
		DRAWING NUMBER DS-21D

CURB RAMPS NOTES:

1. REMOVAL OF EXISTING CONCRETE CURB, GUTTER, SIDEWALK AND PAVEMENT FOR PEDESTRIAN RAMP INSTALLATION SHALL COMPLY WITH SAN DIEGO REGIONAL STANDARD DRAWING G-11. CONSTRUCTION OF CURB RAMPS ON EXISTING SIDEWALKS MAY REQUIRE REMOVAL OF ADDITIONAL SIDEWALK TO COMPLY WITH ADA REQUIREMENTS FOR MAXIMUM GRADES.
2. CURB RAMP CONCRETE SHALL CONSIST OF CLASS 520-C-2500 CONCRETE AND SHALL BE FINISHED WITH A MEDIUM TO HEAVY BROOM TEXTURE FINISH, PERPENDICULAR TO THE AXIS OF THE RAMP.
3. AREAS SHOWN WITH:  ARE THE MINIMUM REQUIRED FOR A COMPLETE RAMP INSTALLATION.
4. IF OBSTRUCTIONS SUCH AS INLETS, UTILITY POLES, FIRE HYDRANTS, ETC., ARE ENCOUNTERED, THE RAMP LOCATIONS MAY BE ADJUSTED UPON APPROVAL BY THE RESIDENT ENGINEER OR INSPECTOR.
5. THE RAMP SLOPES WILL BE MEASURED RELATIVE TO THE SIDEWALK SLOPE. ADJOINING SLOPE BEYOND RAMP SHALL NOT EXCEED 20:1 (5%).
6. LANDING CROSS SLOPE SHALL BE 2.0% MAX.
7. EDGE OF TRUNCATED DOME PANEL SHALL BE LOCATED 6" MINIMUM AND 8" MAXIMUM FROM THE GUTTER FLOW LINE. SEE DETAIL B ON DRAWING DS-21F.

DETECTABLE WARNING SURFACE (TRUNCATED DOME)

8. TRUNCATED DOMES ARE A DETECTABLE WARNING SURFACE CONSISTING OF A CAST IN PLACE PREFABRICATED PANEL COMPOSED OF VITRIFIED POLYMER INCLUDING ALUMINUM OXIDE, SOUND AMPLIFYING, MATERIAL SUCH AS "ARMORE-TILE CAST-IN-PLACE TACTILE PANELS" OR APPROVED EQUAL.
9. THE CONTRACTOR SHALL SUBMIT PRODUCT INFORMATION, INSTALLATION INSTRUCTIONS AND TWO (2) PANEL SAMPLES (MINIMUM SIZE 6"X 8" EACH) TO THE COUNTY FOR APPROVAL PRIOR TO ORDERING OR INSTALLING MATERIALS.
10. DETECTABLE WARNING SURFACE SHALL BE APPROVED IN WRITING BY THE ENGINEER PRIOR TO ORDERING.
11. DETECTABLE WARNING SURFACE SHALL BE DARK GREY CONTRASTING IN COLOR FROM MINOR CONCRETE CURB RAMP THE CONTRAST SHOULD BE AT LEAST 70%. THE CONTRAST IN PERCENT IS DETERMINED BY:

$$\text{CONTRAST} = ((B1 - B2) / B1) \times 100, \text{ WHERE}$$

B1 = LIGHT REFLECTANCE VAUE (LRV) OF THE LIGHTER AREA
 B2 = LIGHT REFLECTANCE VAUE (LRV) OF THE LIGHTER AREA

NOTE THAT IN ANY APPLICATION BOTH WHITE AND BLACK ARE NEVER ABSOLUTE; THUS, B1 NEVER EQUALS 100 AND B2 IS ALWAYS GREATER THAN ZERO.
12. A CERTIFICATE OF COMPLIANCE SHALL BE FURNISHED TO CERTIFY THAT THE DETECTABLE WARNING SURFACES CONFORM TO THE AMERICANS WITH DISABILITY ACT ACCESSIBILITY GUIDELINES (ADAAG) AND REQUIREMENTS. THE CERTIFICATE OF COMPLIANCE SHALL INCLUDE A FIVE (5) YEARS WRITTEN MANUFACTURERS WARRANTY.
13. DURING TILE INSTALLATION AND CONCRETE CURING STAGE, IT IS IMPERATIVE THAT THERE IS NO WALKING, LEANING OR EXTERNAL FORCES PLACED ON THE PANEL TO ROCK THE PANEL, CAUSING A VOID BETWEEN THE UNDERSIDE OF PANEL AND CONCRETE.
14. THE TOP DIAMETER OF EACH TRUNCATED DOME SHALL BE BETWEEN 50% MINIMUM AND 65% MAXIMUM OF THE BASE DIAMTER.

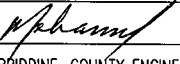
DRAWN BY: <u>SS</u>	CHECKED BY: <u>SMB</u>	SAN DIEGO COUNTY DESIGN STANDARD	REVISION	APPROVED	DATE
RECOMMENDED BY: <u>JEFF S. MOODY</u>					
APPROVED BY: 		GENERAL NOTES FOR CURB RAMPS			
MOHAMAD FAKHRIDDINE, COUNTY ENGINEER					
RCE# <u>44520</u> EXP. <u>03/31/08</u>			DRAWING NUMBER DS-21E		

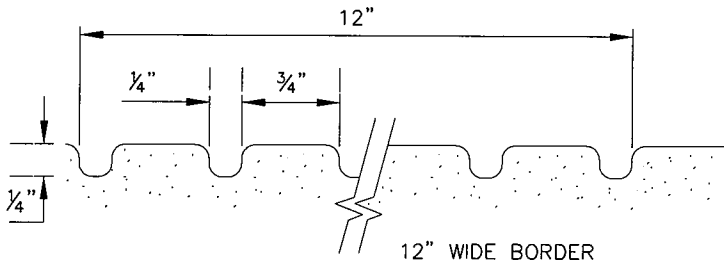
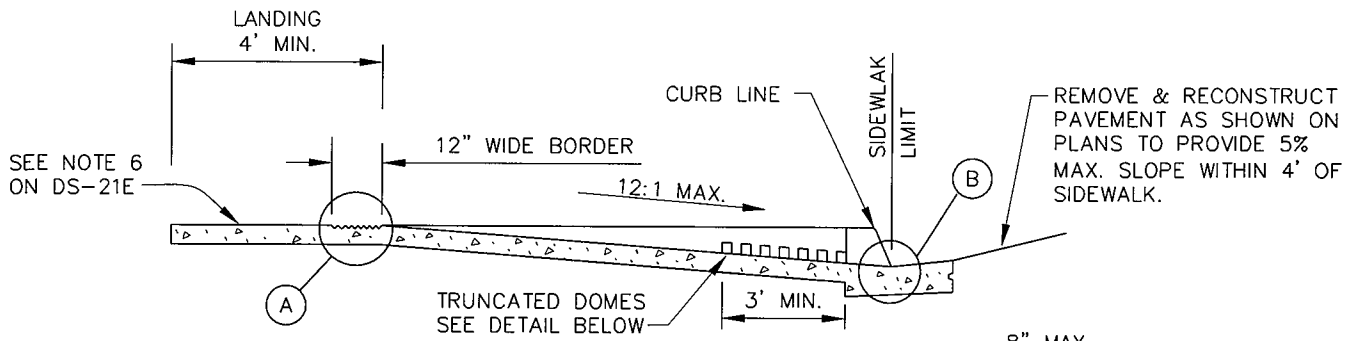

DETAIL A
NOT TO SCALE

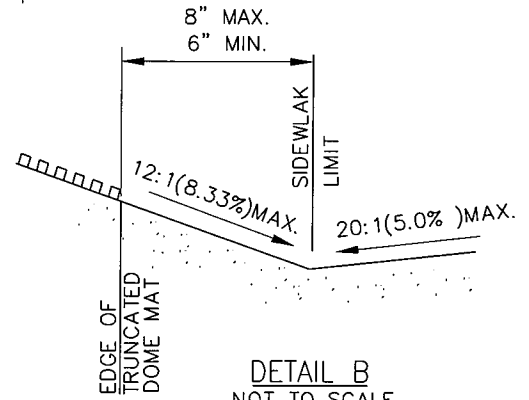

DETAIL B
NOT TO SCALE

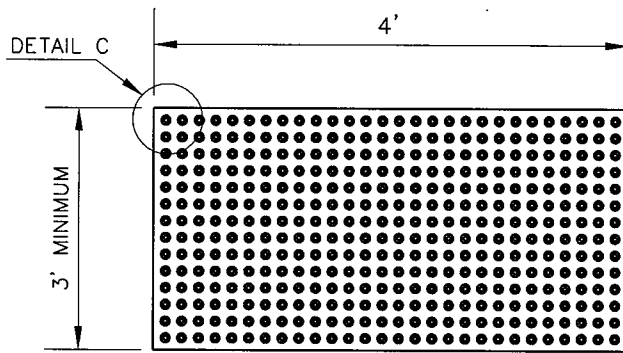

TRUNCATED DOME PANEL
NOT TO SCALE

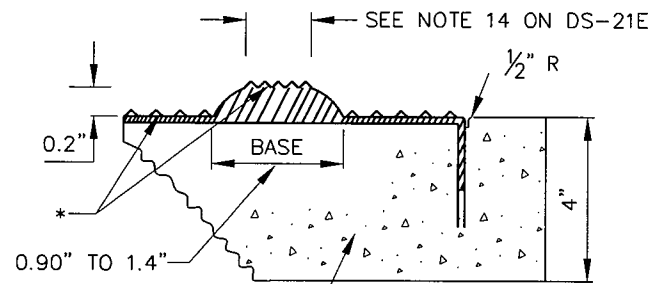

DETAIL D
NOT TO SCALE

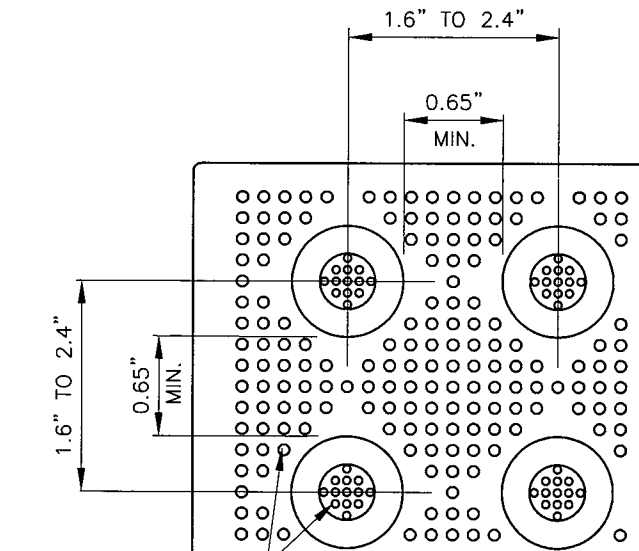

DETAIL C
NOT TO SCALE

PATTERN, SIZE & ORIENTATION OF DOMES SHALL BE PER MANUFACTURER'S RECOMENDATION. SEE NOTE 12 ON DS-21E

DRAWN BY: SS CHECKED BY: SMB

RECOMMENDED BY: JEFF S. MOODY

APPROVED BY: Mohamad

MOHAMAD FAKHRRIDDINE, COUNTY ENGINEER

RCE# 44520 EXP. 03/31/08

SAN DIEGO COUNTY DESIGN STANDARD

CURB RAMP DETAILS

REVISION	APPROVED	DATE
DRAWING NUMBER		DS-21F

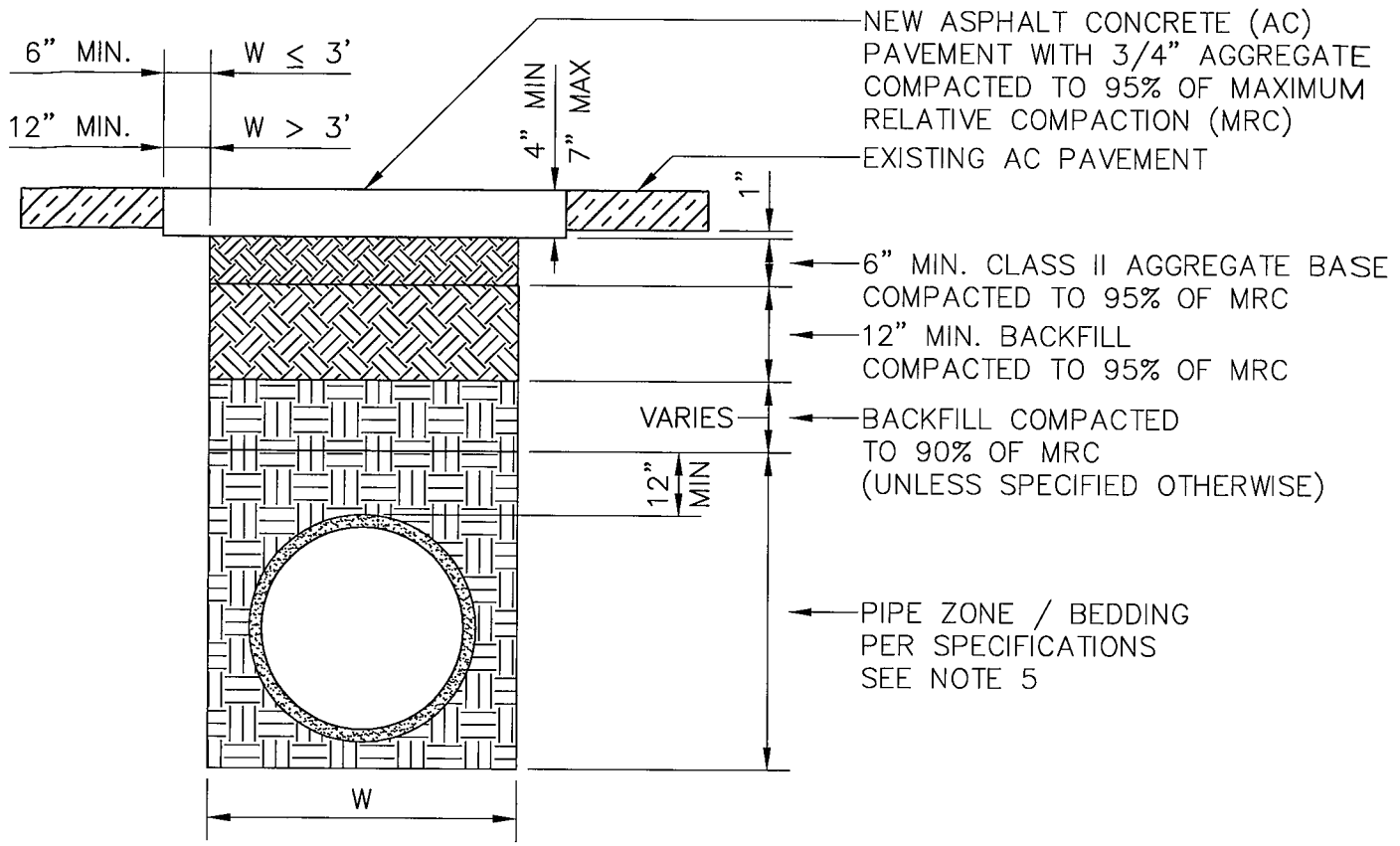

PHASE I - BASE PAVING

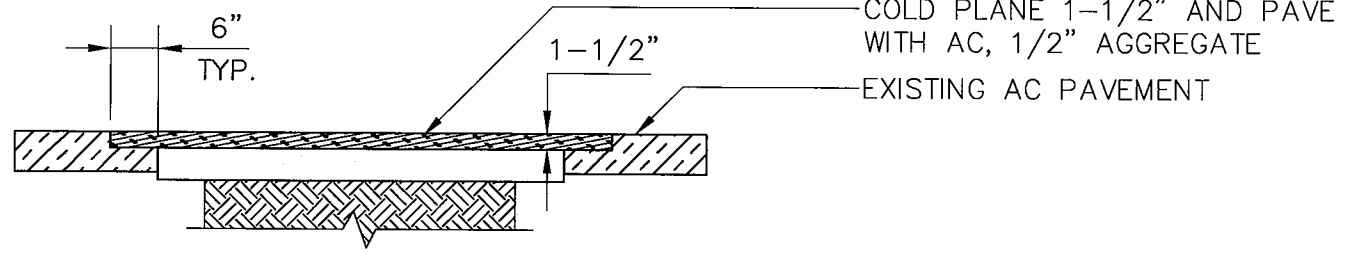

PHASE II - FINISH PAVING

DRAWING NOT TO SCALE

NOTES:

1. PAVEMENT MATERIAL AND SURFACING SHALL MATCH EXISTING.
2. ALL REMOVED SURFACE IMPROVEMENTS (CURBS, DIKES, SIDEWALKS, ETC.) SHALL BE REPLACED IN KIND.
3. ALL AREAS OF EXISTING AC LESS THAN 48" WIDE REMAINING AFTER TRENCHING SHALL BE COLD PLANED AND PAVED PER PHASE II FINISH PAVING.
4. PHASE I PAVEMENT THICKNESS SHALL EQUAL EXISTING PAVEMENT THICKNESS PLUS 1" (4" MINIMUM / 7" MAXIMUM).
5. WHEN GRAVEL OR ROCK IS USED WITHIN THE PIPE ZONE, THAT MATERIAL SHALL BE ENCAPSULATED IN A FILTER FABRIC ENVELOPE WITH $W/2 \geq 12"$ MINIMUM OVERLAP. THIS REQUIREMENT APPLIES ONLY TO TRENCHES UNDER OR WITHIN 10' OF SURFACING.
6. PHASE II PAVING SHALL BE COMPLETED NOT EARLIER THAN 14 CALENDAR DAYS AND NOT LATER THAN 75 CALENDAR DAYS AFTER PHASE 1 PAVING.
7. FOR PCC PAVEMENT REFER TO RSD G25.

DRAWN BY: <u>PME</u>	CHECKED BY: <u>JSM</u>	SAN DIEGO COUNTY DESIGN STANDARDS	REVISION	APPROVED	DATE
RECOMMENDED BY: <u>J. MOODY</u>				<i>mkt</i>	11/4/09
APPROVED BY: <i>Mohamad</i>		TRENCH RESURFACING TYPE-R			
MOHAMAD FAKHRRIDINE, COUNTY ENGINEER			DRAWING NUMBER	DS-22	
RCE # 44520	EXP. 3/31/10				